



## **701TXV**

Vibration Analyzer

User's manual

701TXV.00.000.UM

## TABLE OF CONTENTS

General Precautions .....	6
EC Declaration of Conformity .....	7
System set .....	9
Specifications .....	10
Basics .....	11
Keypad .....	11
Battery charging .....	12
Main Menu .....	13
Setup Menu .....	13
Vibration Analyzer. Vibration menu .....	16
Setting Spectrum Analyzer Parameters .....	16
Units .....	16
Sensor .....	17
Setting the Sensor Conversion Factor .....	17
Setting the HPF cut-off frequency .....	18
Setting the LPF cut-off frequency .....	18
Setting the number of FFT lines .....	19
Setting the FFT window type .....	19
Trigger Type .....	19
Set the Averaging mode .....	20
Confirmation of Spectrum Analyzer parameters .....	20
Starting a Measurement .....	21
Controls in measurement mode .....	21
Bump test .....	22
Record measurement files .....	29
Route-based measurements .....	30

Bearings tester.....	31
Shock Pulse measurement.....	31
Kurtosis .....	33
Operation .....	33
Measurement .....	34
To save report file .....	35
To open report file .....	35
IR Thermometer .....	36
Balancing.....	37
Setup Balancing parameters .....	37
Balancing in one plane .....	40
One-Plane Balancing Procedure Overview .....	41
Example: Balancing procedure flow (one plane, two points).....	41
Using optional accessories .....	45
Stroboscope .....	45
Eddy Current Probe.....	45
Firmware Upgrade.....	46
Firmware Upgrade using pen drive .....	46
Firmware Upgrade Using Windows Mobile Device Center .....	48
Laser Alignment System. General.....	50
Safety Precautions .....	50
Laser Safety Precautions.....	50
Technical Description .....	51
Designation .....	51
Misalignment Parameters.....	52
Specification and Features.....	53
System Package.....	54

System overview .....	54
Mounting Transducers .....	55
Laser Beam Adjustment .....	56
Getting Started .....	57
Common control keys consideration .....	57
Auto save .....	57
Device setup.....	57
Setup Menu Items.....	58
Horizontal Machine Alignment.....	60
Short Explanation.....	60
Transducer's Positions Conventions .....	60
Parameters.....	61
Tolerance Setup .....	62
Taking Measurements. Clock Mode .....	63
Taking Measurements. Multipoint Mode.....	65
Taking Readings. Auto Shooting mode .....	65
Readings quality assessment .....	66
Editing of measurement points .....	66
Result Screen .....	67
Movable machine Adjustment .....	68
Machines with Spacer Shaft .....	69
Lock Feet Pair .....	70
Report file saving .....	71
Soft Foot .....	73
Vertical Machine Alignment.....	75
Short Explanation.....	75
Transducer's Positions Conventions .....	75

Parameters.....	76
Taking Measurements. Clock Mode .....	77
Result Screen .....	78
Machine Correction @45.....	80
Charging batteries.....	81
Firmware Upgrade .....	82
Firmware Upgrade Using Windows Mobile Device Center .....	84
Standard Tolerances of Shaft Misalignment .....	86
Delivery Set.....	87

## GENERAL PRECAUTIONS

To prevent possible electrical shock, fire, injury, or damage to the device:

Read the user manual carefully.

Do not place the sensor on objects subject to high voltage. Failure to comply may result in injury or death.

The analyzer cannot be used in potentially explosive environments.

Take measures to prevent cables from getting into rotating parts of machines at the measuring point.

Do not expose the 701TXV to strong shocks, high humidity, or extreme temperatures.

Do not attempt to open the display as this may damage the system and void your after sales warranty.

The analyzer is serviced by one operator who has undergone special training and safety briefing when working with mechanisms and machines that have rotating parts, as well as when working with laser radiation sources.

Operation of the analyzer is allowed only after familiarization with this OM.

The analyzer supplier is not responsible for the misuse of the equipment, nor for the interpretation of the measurement results.

This user manual may contain inaccuracies or typographical errors. We will be grateful if you report them to the email: [info@alvibco.com](mailto:info@alvibco.com). We will also be happy to receive your suggestions and wishes regarding the improvement of the analyzer and this manual.

## EC DECLARATION OF CONFORMITY

Manufacturer: ALVIB Sistemas S.L., VAT: ES B10840346

Escorpora 24, 17252, Sant Antoni de Calonge, Spain

Product name: 701TXV

Description: Vibration Analyzer cum Laser shaft alignment and geometrical measurement system

Model(s): 701TXV, 701TXV-C2, 701TXV-C4, 701TXV-5C2, 701TXV-5C4

This declaration of conformity is issued under the sole responsibility of the manufacturer.

The object of the declaration described above is in conformity with the relevant Union harmonization legislation:

- 2014/30/EU – Electromagnetic Compatibility (EMC Directive)
- 2014/35/EU – Low Voltage Directive (LVD)
- 2011/65/EU – Restriction of Hazardous Substances (RoHS), including amendment (EU) 2015/863
- 2014/53/EU – Radio Equipment Directive (RED)

References to the relevant harmonized standards used:

EMC: EN 61326-1:2013, EN 55011:2016/A1:2017, EN 61000-6-2:2019,  
EN 61000-6-4:2019

Electrical Safety (LVD): EN 61010-1:2010/A1:2019

Laser Safety: EN 60825-1:2014 (Laser Class 2)

RoHS: EN IEC 63000:2018

Radio: EN 300 328, EN 301 489-1, EN 301 489-17

Additional information:

The product incorporates low-power visible laser sources classified as Class 2, safe under reasonably foreseeable conditions of operation.

Signed for and on behalf of:

Place of issue: Sant Antoni de Calonge, Spain]

Date: 1 July, 2022

Name: Oleg Ivanov

Position: Director

Company: ALVIB Sistemas S.L.

Signature:



## Overview

The 701TXV Vibration Spectrum Analyzer (hereinafter referred to as analyzer) is a compact yet powerful instrument for overall vibration measurements, vibration spectrum analysis of rotating equipment, immediate ISO 10816 evaluation, route and off-route data acquisition, balancing of rotary machinery. Route files and data file sharing via email make it ideal for collecting data from remote sites. Easy to use, with free firmware updates, comes with data management and reporting software.

Optionally, the analyzer can be completed with measuring units and a set of accessories for high-precision laser alignment of horizontal and vertical mechanisms, geometric measurements.

## System set

The 701TXV kit includes:

- 701TXV display unit;
- Accelerometer, cable 1.5 m, magnet for mounting on a curved surface - 2 or 4 pcs;
- Optical sensor, magnetic stand;
- USB charger;
- USB cable;
- ConSpect software and User Manual on the device drive;
- Carry case for transportation and storage.

Optional, when ordering the version with Laser Alignment System:

- Sensors S, M with cables or wireless;
- Universal V-brackets with chains;
- Rods 100mm, 150mm;
- Tape measure 3m.



## Specifications

**Input** - 2 or 4 inputs for connecting IEPE or charge type accelerometers with known sensitivity, switchable. Optical sensor input.

**ADC converter** - 24 bits

**Frequency range** - 1... 50000 Hz

**Vibration measurement range (depends on used accelerometers):**

**Acceleration** - 200 m/s<sup>2</sup>

**Speed** - 200 mm/s

**Displacement** - 2000  $\mu$ M

**Accuracy** - 5%

**FFT spectrum resolution** - 100, 200, 400, 800, 1600, 3200, 6400, 12800, 25600, 51200, 102400 lines

**Balancing** – up to 8 planes, up to 16 points

**Speed measurement range** - 10... 200000 rpm

**Accuracy** –  $\pm 0.1\%$  and  $\pm 1$ rpm

**Temperature measurement range** (\*Optional function) –  $-70^{\circ}\text{C}$  to  $380^{\circ}\text{C}$ .

**Accuracy** –  $\pm 0.5\%$  ( $0...+60^{\circ}\text{C}$ ),  $\pm 1\%$  ( $-40...+120^{\circ}\text{C}$ ),  $\pm 2\%$  ( $-70...+180^{\circ}\text{C}$ ),  $\pm 4\%$  ( $-70...+380^{\circ}\text{C}$ )

**Bearings Tester** (\*Optional function) – measurement range 120 dBa, ( $-30...+90$ dB)

**Accuracy** -  $\pm 5$  dB

**Laser Alignment System** (\*Optional function) – shaft alignment, geometrical functions

**Storage** - 4 GB, micro-SD card

**PC interface** - USB

**Display** - color, sunlight readable,  $\frac{1}{4}$  VGA 3.5", \*optional 480x800, 5" version

**Battery** - Li-Ion rechargeable, up to 8 hours of continuous operation

**Dimensions** - 220 x 102 x 40 mm

**Weight** - 470 g

## BASICS

### Keypad

To turn the display unit on and off - press and hold the power button  for ~2 seconds.

In the event of a system freeze, when the device does not respond to any keys - press and hold the power button  for ~ 10 seconds, the system will be reset and restarted.

To close any currently active window without saving, other than the device's main menu, press the  button (it serves as the backspace key).

The  button in most cases is used to apply (save) changes (selection) and exit (from editing windows or from the current window).

### Autosave

All procedures are designed with automatic saving. To temporarily interrupt the current work, press  key, you will exit to the main menu of the device. The data of the interrupted measurement will be automatically saved, and the device can be turned off.

## Battery charging

The battery can be charged with a USB charger or via the USB port of a PC/laptop.

Immediately after connecting the charger to the display unit, there are a few seconds to change the charge current - press and hold the  button for ~2 seconds until the LED changes the flash rate.



Low speed flash - normal charge, high speed - fast charge. Keep in mind that the PC/Laptop USB port can only provide a normal charge.

When the battery is fully charged, charging will stop, and the LED will turn off. Recharging does not occur even if the USB cable remains connected.

## Main Menu

After turning on the device, the main menu is displayed on the screen.

To call a menu item - move the cursor to this item and press the  key .

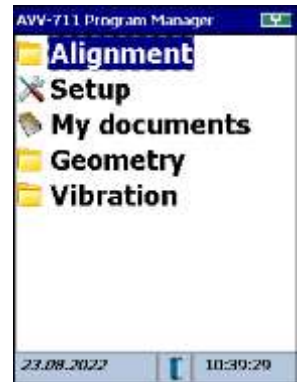

## Setup Menu

To invoke the configuration menu - move the cursor and press the  button.

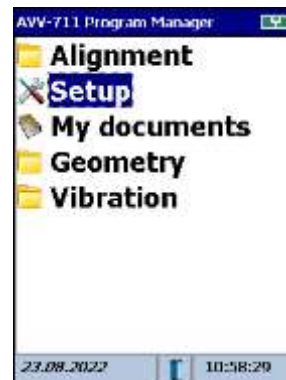

– date and time setup





– auto off delay time. Is disabled when set to 0





3. license manager

– to install a license file that enables measurement functions. Press ,

navigate to the license file, then press  to open and install the licenses.



+ Feature is on, valid until 01.01.2099

Serial number



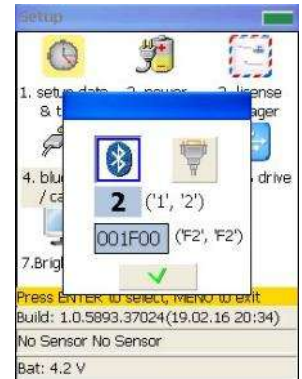

4. wireless /cable

– to switch between wireless/cable transducer's connection.



5. language

– Language of the user interface

Use the   keys to select the language, then press 



6. USB drive

– to switch the device to USB storage

device mode. By default, a device can be connected to a PC via Microsoft Windows Mobile Device Center. USB storage device mode can be used as an alternate mode.





– Adjusting the brightness of the display backlight

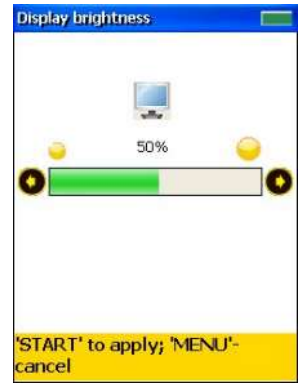

- to select the default alignment mode – 1-d or 2-d dual-axis mode. In the dual-axis mode, both horizontal and vertical alignment of the machine with real-time data updates can be performed in the static position of the transducers (e.g., 3 hours). For QB-TSM sensors, the only available mode is 1-D.



# VIBRATION ANALYZER. VIBRATION MENU

Move the cursor and select the mode.



## Setting Spectrum Analyzer Parameters

To enter the analyzer parameters change menu - press **F1**.

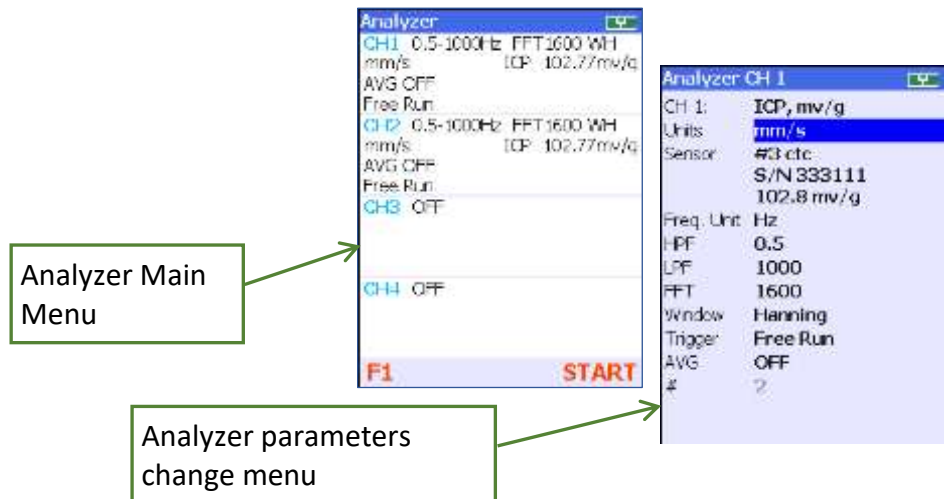

## Units

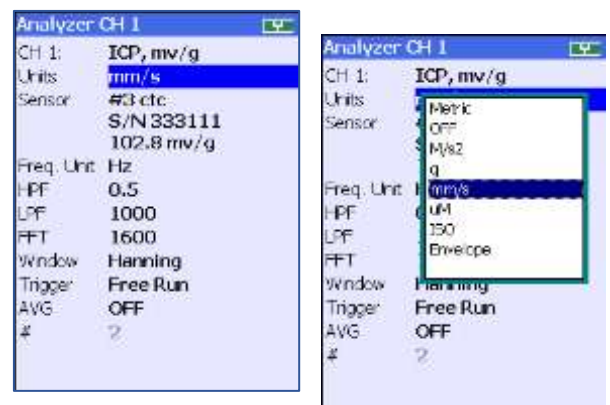

Move the cursor to Units and click **ENTER**.

Use the **↑** **↓** keys to select units of measurement – for example, **mm/s** and press **ENTER** to confirm.



## Sensor



Move the cursor to the **Sensor** and press 

Use the   keys to select the type of sensor – for example, **ICP** and press  to confirm.



## Setting the Sensor Conversion Factor

Move the cursor to the **Sensor** and press 

Use the   keys to select the sensor parameter that you want to change, such as Serial Number (C/N), and then press .

Enter the new value from the keyboard and press  to confirm. To confirm the new

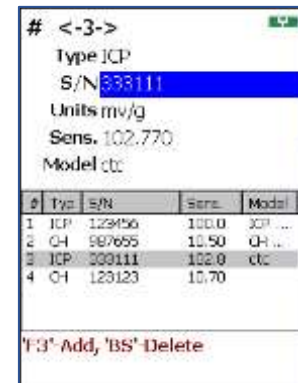

sensor settings, press .



### Setting the HPF cut-off frequency

Move the cursor to

the **HPF** and press .

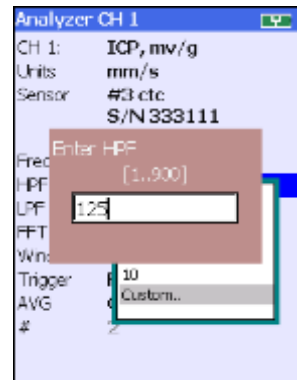

Use the   keys to select the desired frequency of the HPF – for example **2 Hz** and press  to confirm.



It is possible to select the preset values of the HPF - **0.5, 1, 2, 5, 10 Hz**. To enter an arbitrary value in the range of **1... 720 Hz** – select **Custom..**

### Setting the LPF cut-off frequency

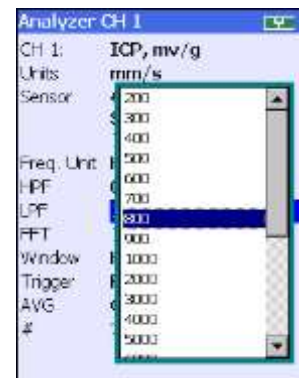

Move the cursor to the **LPF** and press .

Use the   keys to select the desired LPF frequency – e.g. **800 Hz** and press  to confirm.



### Setting the number of FFT lines

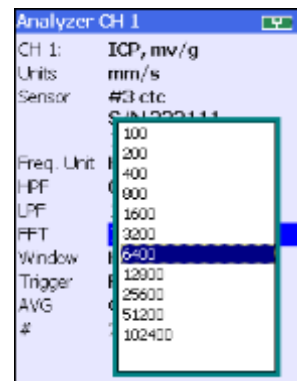

Move the cursor to the **FFT** and press .

Use the   keys to select the required number of FFT lines – for example **6400** and press  to confirm.



### Setting the FFT window type

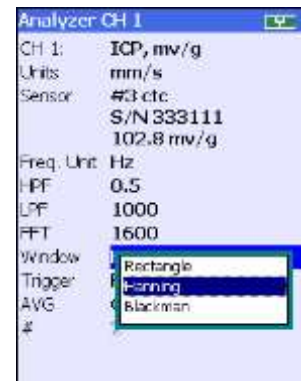

Move the cursor to **Window** and press .

Use the   keys to select the desired FFT window – for example **Hanning** and press  to confirm.



### Trigger Type



Move the cursor to **Trigger** and press .

Use the   keys to select the desired type of measurement start – for example **Free run** and press  to confirm.



## Set the Averaging mode

Move the cursor to **Averaging** and press .

Use the   keys to select the desired averaging type – for example, **Lin FD** (Linear, Frequency Domain) and press  to confirm.

Then select the number

of measurements to be averaged and press  to confirm.

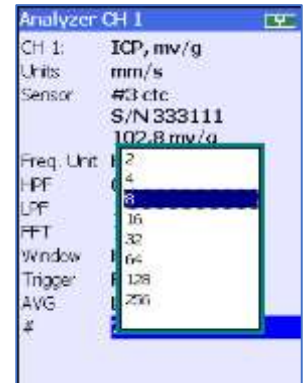

## Confirmation of Spectrum Analyzer parameters

After the measurement parameter settings

are completed, press  to confirm and return to the main menu of the analyzer.



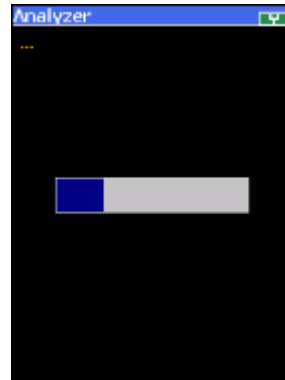

## Starting a Measurement

Install the sensors on the measurement object and press the  key.





## Controls in measurement mode

 - Switching between FFT and Time function modes

 - stop/resume measurement

 - select the channel in which the cursor is active

 - cursor movement (measurement must be stopped by pressing )

 - setting the cursor to the maximum harmonic of the spectrum

 - cursor type switching – **frequency/cycles per minute/harmonic number**

 - change the display mode on the display

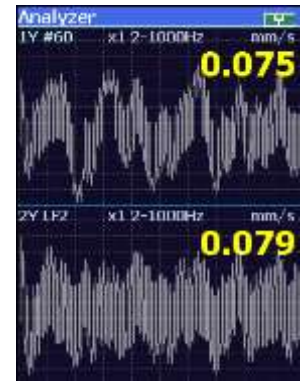

## Bump test

The bump test is an effective vibration analysis method used to identify resonance frequencies within a machine's structure. This test involves striking the machine's structure while it is stationary and simultaneously performing a measurement. Proper selection of the hammer or mallet, as well as the force and direction of the impact, is crucial to introduce appropriate frequencies without causing damage.

To conduct measurements:

- set Trigger to Internal
- set appropriate parameters
- start measurement

Analyzer CH 1	
CH 1:	ICP, mV/g
Function	FFT
Units	M/s <sup>2</sup>
Sensor	#1 ICP Def S/N 123456 100.0 mV/g
HPF(Hz)	10
LPF(Hz)	2000
FFT	400
Window	Rectangle
Trigger	Internal
AVG	EXP FD
#	8

Device will take readings every time object under test is bumped

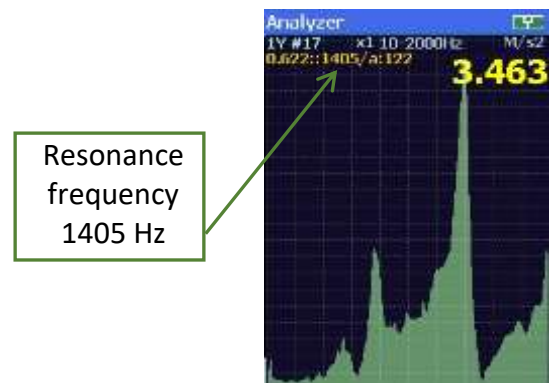
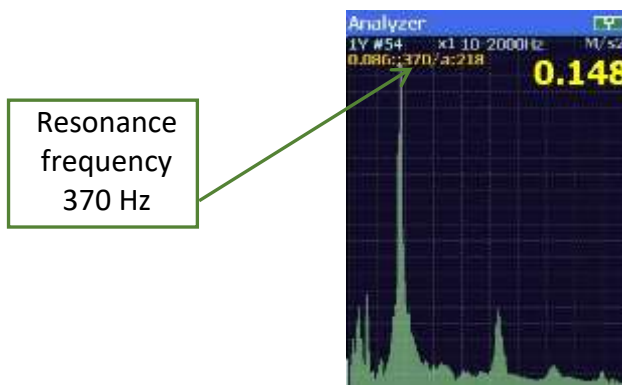

## RUN-UP / COAST-DOWN (RUCD)

The 701TXV Run-Up / Coast-Down (RUCD) module is used to record and analyze vibration signals during machine run-up, coast-down, and other transient operating conditions.

The module simultaneously records vibration signals and the tachometer signal, storing the result as a standard Microsoft Windows **.wav** waveform file. The recorded data can be analyzed using various processing and display options.



### General Notes

Correct tachometer pulses are required for accurate RPM and phase measurement. Proper tachometer installation is essential.

If phase measurement is not required, recording can be started manually.

**Note:** Set 'RPM to .wav' to 'No' for manual recording mode.







### Common Features

Measurement parameters:

- Number of channels: 1 to 3
- Frequency range:
  - 1...3125 Hz (up to 30,000 RPM), sampling at 8000 Hz
  - 1...6250 Hz (>30,000 RPM), sampling at 16000 Hz
- Effective RPM range: 30...120,000 RPM
- FFT lines: 100...102400
- Maximum recording time: up to 3000 s (limited by SD card capacity)

## Set Parameters



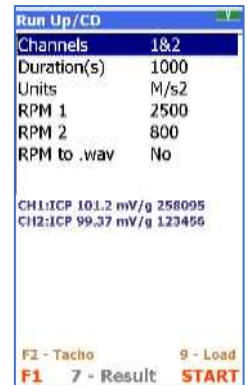

### Key Shortcuts

Key	Function
	Edit selected parameter
	Sensor setup
	Check tachometer
	Open recording window
	Open result window
	Load .wav file





**Note:** If RPM = 0, system waits for manual start.

### To set working channels:

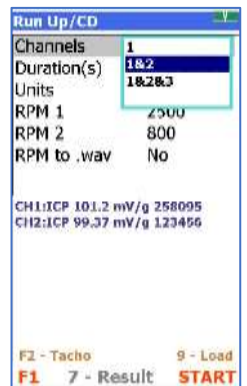
- Press 
- Use   to select working channel
- Confirm with 



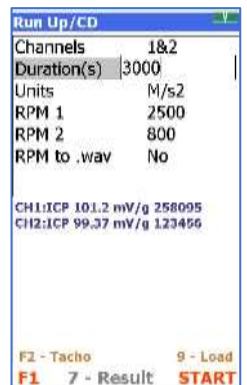

### To set the record duration (in sec):

- Press 
- Enter duration
- Confirm with 



### To set RPM 1 and RPM 2 (start and stop RPM):

- Press 
- Enter RPM
- Confirm with 

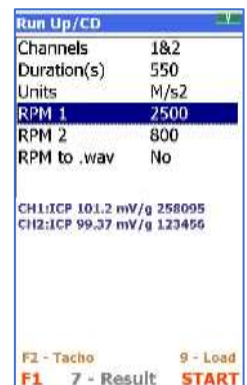



To enable or disable the tachometer data recording (RPM to .wav):

- Press  to toggle between YES and NO



To configure sensor type and sensitivity:

- Press  to open the Settings menu
- Press  to access Sensor Settings
- Press  to exit



Before starting the measurement, press  to verify the tachometer reading and confirm signal stability.

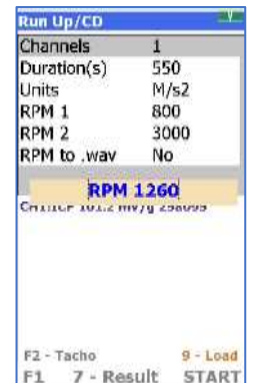

## Data Recording Window

### Key Shortcuts

Key

Function



Start recording manually



Exit recording

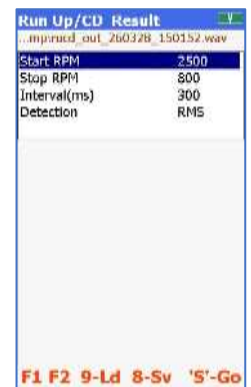









The screenshot shows a window titled "Run Up/CD Result". It displays the following parameters:

Parameter	Value
Start RPM	2500
Stop RPM	800
Interval(ms)	300
Detection	RMS

At the bottom of the window, the text "F1 F2 9-Ld 8-Sv 'S'-Go" is visible.

# Result Window

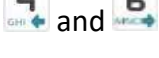
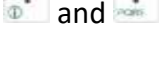
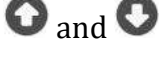
## Key Shortcuts

Key	Function
	Analyze data
	Switch focus
	Bode plot
	FFT plot
	Load file
	Save CSV/PDF
	Change channel
	Change slice
	Chart plot navigation
	Hold for continuous Chart plot navigation

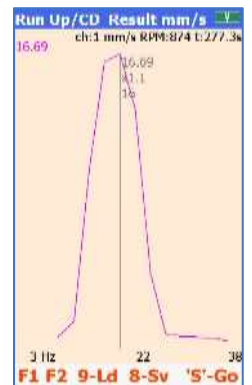
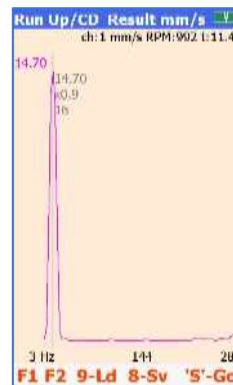
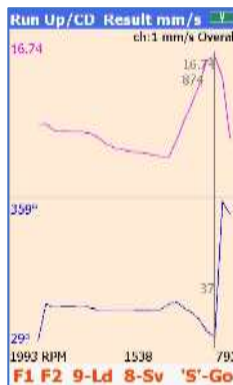
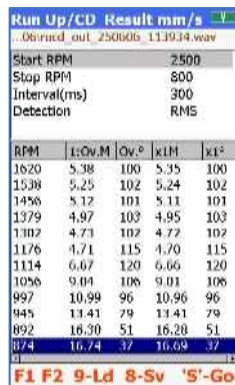
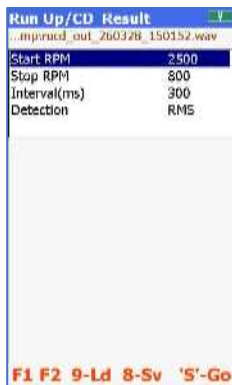

## WAV File Format

Data is stored in IEEE Float 32-bit WAV format with additional custom metadata chunk ('koh\_').

Integrator modes:

- 0 – Acceleration (m/s<sup>2</sup>)
- 1 – Velocity (mm/s)
- 2 – Displacement (μm)

## CSV Export Format

CSV file contains processed slice data including RPM, overall level, phase, and harmonic components.

Conversions:

- RMS =  $0.7071 \times \text{magnitude}$
- Peak-to-Peak =  $2 \times \text{magnitude}$

Phase is given in degrees.

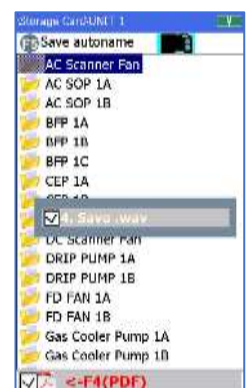

## RECORD MEASUREMENT FILES

To save a file - press a  key in the results menu.

Files can be saved on the internal SD card or on the flash drive connected to the USB host connector of the device.

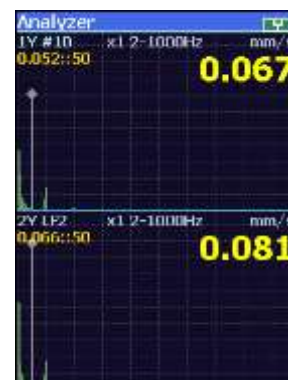

Use  to select a disk

Use       to select a folder



Use  to open a folder

Use  to move up one level

Use  to create a new folder

Use  for ON/OFF generation of reports in PDF format

Press  or  to write a report file with a default name

Press  to edit the file name, then click  to write the file

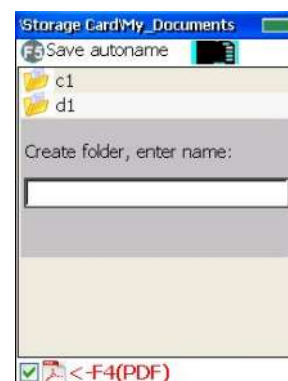
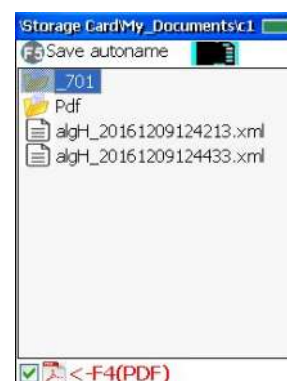
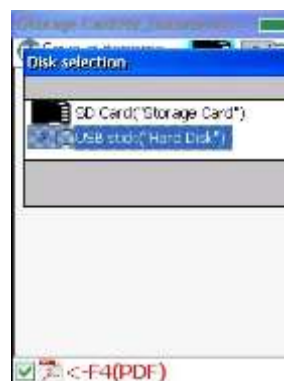

## ROUTE-BASED MEASUREMENTS



Use ConSpect software to create a route and upload the route file to the device

Go to the **Vibration/Route** menu, press 

Device will enter the file explorer.



Open the folder with the route file, place the cursor on the ROUTES.SRC file and click .

Use   to review or randomly select route points

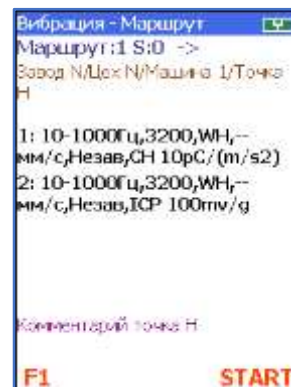

Set the sensor at the measurement point and press . The instrument performs the measurement with the specified parameters and saves the files to the destination folder corresponding to the route point.

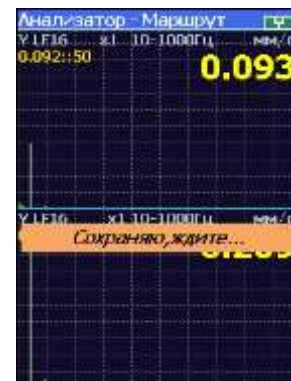

## BEARINGS TESTER

Bearings tester function is based on shock pulse measurement and Kurtosis measurement.

### Shock Pulse measurement

The most favorable conditions for the operation of bearings occur when their components are separated by a film of lubricant that prevents collisions. However, manufacturing defects, in-service damage, contamination, lack or absence of lubrication create conditions for collisions of bearing elements, resulting in acoustic vibrations in a wide range of frequencies in the bearing body – so called shock pulses.

Even a new bearing is a source of shock pulses from the moment it is commissioned, for which the amplitude of the shock acceleration is denoted by dBi.

The dBi value indicates the condition of a new, properly installed and lubricated bearing.

As defects in the bearing develop, the amplitude of shock pulses increases. Value exceeding the dBi characterizes the damage and is used to assess the condition of the bearing:

0..20 - good condition

20..35 – satisfactory condition

>35.. - Poor condition, risk of failure

Depending on the type of damage in the bearing, the nature of the forced oscillations recorded by the device also changes.

When measured, device allows you to distinguish and measure two characteristic values of the shock pulse amplitude – the carpet value - dBc, and the maximum - dBm values.

The carpet value dBc corresponds to frequent collisions of bearing elements and characterizes the state of lubrication. For example, when measuring the impact acceleration amplitude of a well-lubricated and properly mounted bearing, the dBm value will be slightly greater than dBc.



If we measure the amplitude of the impact acceleration of a damaged bearing, they are detected by the maximum values - dB<sub>M</sub>, while the value of dB<sub>C</sub> depends on the state of lubrication and can increase greatly with a lack of lubrication, accompanied by frequent metal-to-metal contacts. An example of a change in the values of these values is shown in Fig.

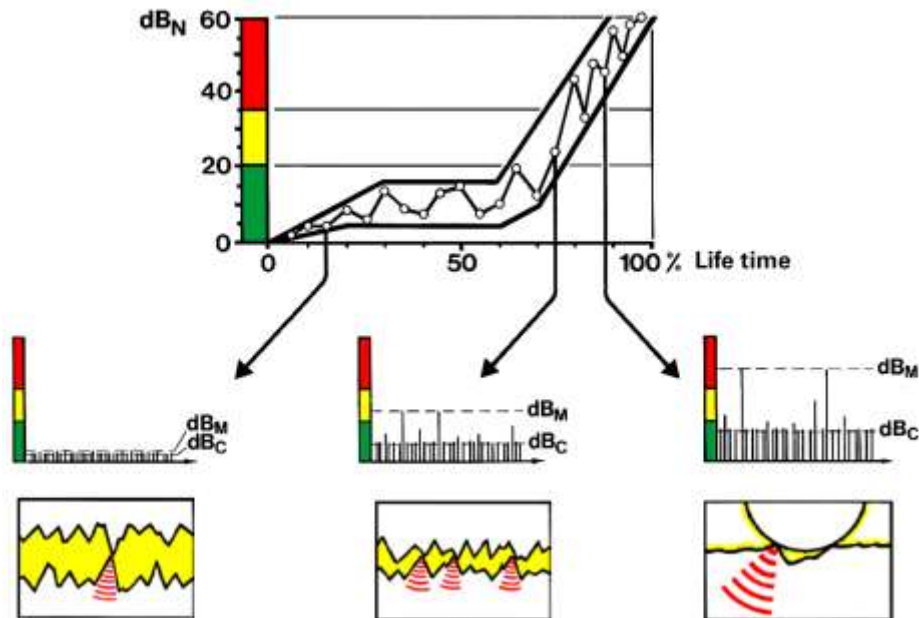

An increase in the carpet dB<sub>C</sub> value can be caused not only by deterioration in the condition of the lubricant, but also by other causes, such as misalignment of the shafts in the coupling of the drive. It is quite easy to distinguish between these phenomena: if the shafts are skewed, the same pattern will be observed for the bearings on both sides of the coupling.

When measuring the amplitude of the shock acceleration of gearbox bearings, the result obtained may be affected by shocks occurring in the gearing, which can be transmitted to the bearings. However, in most cases, the noise of the gears is so low that it does not affect the measurement results.

In the case of impacts resulting from gear defects, the maximum value of dB<sub>M</sub> increases dramatically on both sides of the gear at the same time.

The greatest effect of monitoring the technical condition of bearings is achieved when recording the measurement results with the construction of a graphical dependence in time. At the same time, it becomes possible to predict the technical condition. An example of processing measurement results is given in Table 1 (page 14).

Measurement results can be stored in the device memory.

## Kurtosis

In the case of a serviceable bearing, the probability density of stationary random vibrations that occur in a serviceable bearing due to frictional forces can be considered to be in accordance with the normal law. The appearance of defects accompanied by impacts between the bearing bodies and raceways leads to a change in the shape of the probability density curve  $p(x)$  and, accordingly, to a change in the numerical value of the kurtosis coefficient  $E$ . Moreover, the more developed the defect, the sharper the density curve becomes.

Based on the results of the analysis of a large sample of defective and non-defective bearings, the following threshold values of the kurtosis coefficient were established:

$Ku < 3$  – corresponds to the good condition of the bearing;

$Ku > 3$  – the bearing can be operated until the next replacement;

$Ku > 5$  – the bearing is not allowed to be used.



The statistic index Kurtosis is insensitive to changes in rotational speed and load and does not require knowledge of the bearing size to be diagnosed and repeated measurements. The kurtosis coefficient is sensitive to the lubrication condition of the bearing, so it can also be used to diagnose plain bearings. The Kurtosis measurement cannot identify a defect, so it is recommended to use it at the stage of preliminary assessment of the technical condition of bearings, and to identify and localize defects, use more accurate methods of vibration diagnostics.

## Operation

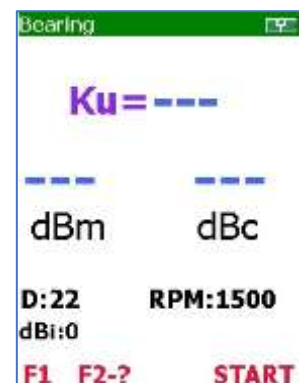
- Enter **Bearings** menu:



To set dBi

- press  key, set dBi value
- confirm by  key
- use  key to calculate dBi value based on D and RPM

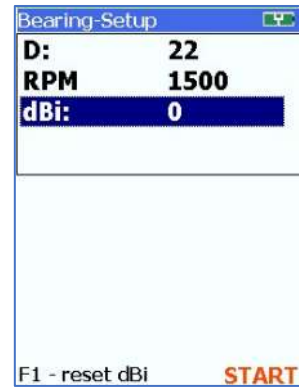

If dBi value is unknown just enter the bearings shaft diameter and RPM then press  key, device will calculate the dBi value:

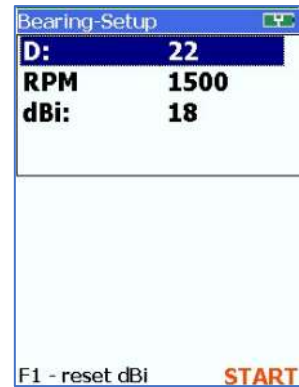



## Measurement

- connect P77B probe to the device socket
- press the probe tip against the measuring point with a pressure force of about 1 kg
- press  key

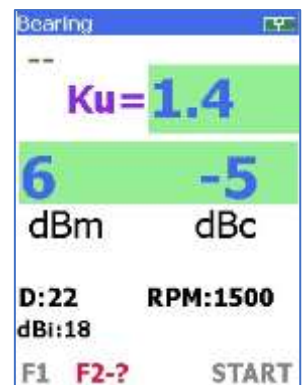
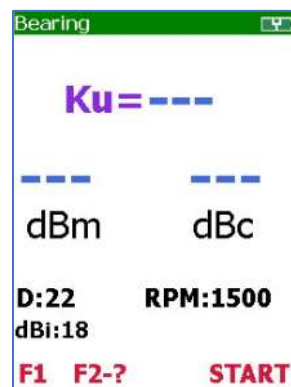

Header color will change to blue when measurement is active.



Measured data is continuously updated until the next press of the  key which will terminate measurement.

To facilitate evaluation of the result, the device displays data on a colored background of green, yellow, or red.





**Green** – corresponds to the good condition of the bearing;

**Yellow** – the bearing can be operated until the next replacement;



**Red** – the bearing is not allowed to be used.

### To save report file

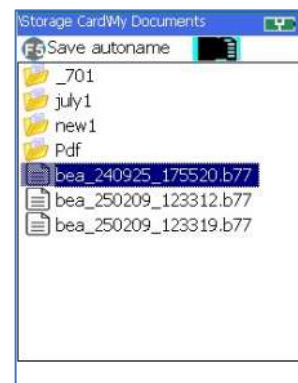
- stop measurement by  key
- press  key
- browse to destination folder, press to  save file



### To open report file

- press  key
- move cursor to file to open, press  key



## IR THERMOMETER

- Enter Thermometer menu
- connect P77T2 probe to the device socket
- aim probe to the object
- use  key to start/stop measurement





# BALANCING

## Setup Balancing parameters

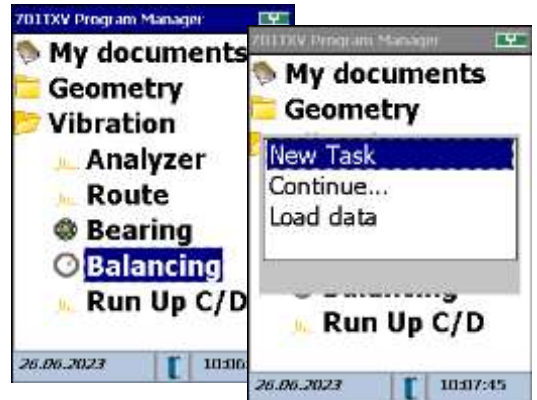
Enter Balancing function.





Use   to choose parameter to setup.

Press  to edit parameter value.



Set **RPM** of the machine at which balancing will be conducted.



It is also possible to run tachometer measurement to get actual machine RPM. Press  to do so, then press  to apply measured RPM.

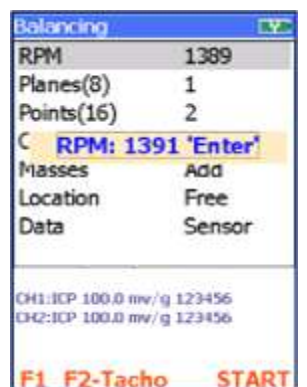



If actual RPM and balancing RPM differs by more than 5% device will display error message while measurement is in progress

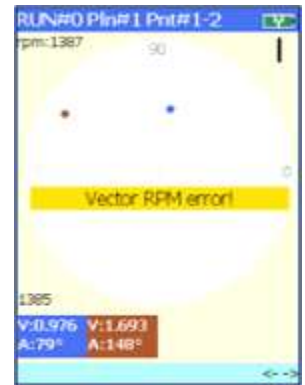

Set number of **Planes** (where correction weights will be attached) and number of **Points** (where the accelerometer will be measuring the vibration levels)

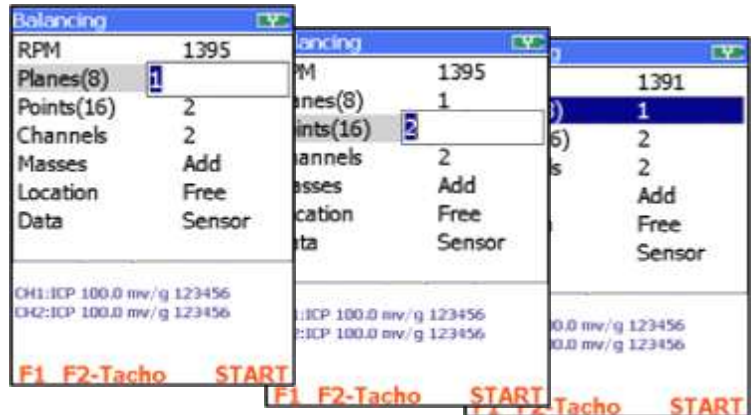

Set number of channels used to take readings.

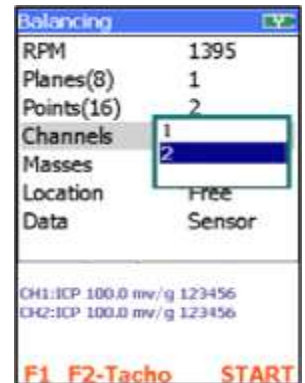

Balancing weights can be preset to **Add** or **Remove**.



Correction weights can be attached at any angular position - **Free Loc.**  
 Or at **Fixed Locations** (e.g., at the fan blades). Number of Fixed locations can be set in the range of 3 to 18 locations.

 *Balancing program assumes that angles (and fixed location numbering) are always calculated **counter wise** machine rotation direction!*

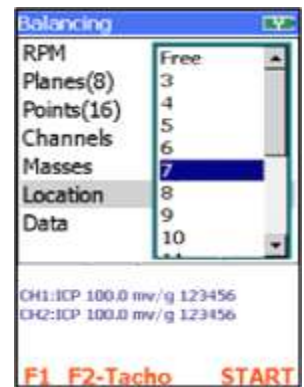

Data source should be set to Sensor.

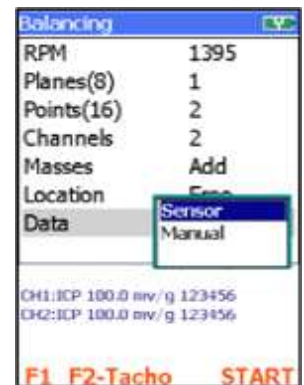

Choose sensors used to take readings.

Press  to confirm.

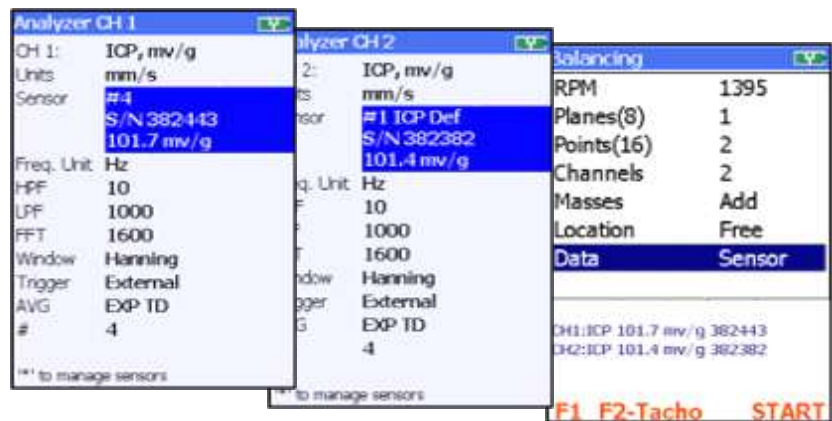

Now all is set, and device is ready for measurement.

Press  to start measurement.

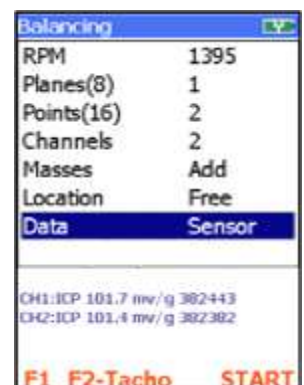

## Balancing in one plane

### **SAFETY PRECAUTIONS**

Vibration measurement and balancing involves measurement on rotating machines. Always keep a safe distance to rotating parts and secure transducers and transducer cables from rotating parts.



Balancing involves mounting of trial and balancing weights on the rotor. Always secure the start switch with a locker and use the emergency switch for double safety before working with the rotor.

This is especially important when the machine is remote controlled.

The device manufacturer cannot take responsibility for any accidents on people and machines.

Heed all warnings and recommendations to prevent data loss, data inaccuracy, damage to the instrument, or injury to yourself!

## One-Plane Balancing Procedure Overview

- Run 0 - the initial vibration (unbalance) measurement.
- Run 1 – vibration measurement with trial weight attached in plane A
- Stop the machine, attach calculated correction weight at the specified angle on balance planes A.

Trim run 1... – Start the machine and measure residual vibration level. Once measurement stopped device will calculate trim weight, to further reduce the vibration. If residual vibration is higher than target value – attach trim weight and perform another trim run. Repeat trim runs until required vibration level is achieved.

### Example: Balancing procedure flow (one plane, two points)

Set Balancing parameters.

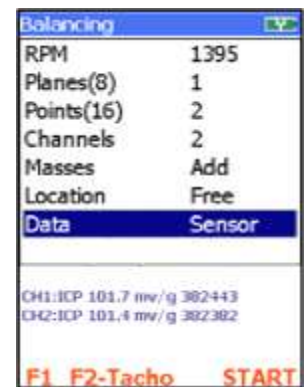

Place accelerometers at measurement points

Run the machine

Press 



Wait reading to stabilize.

Press 

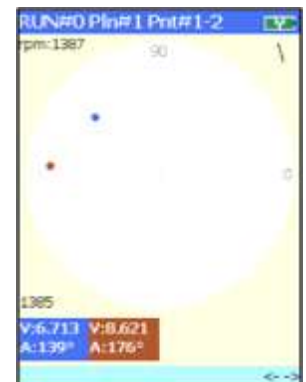

Confirm reading is accepted.

Press 

Stop the machine.



Attach the trial weight.

Enter trial weight and angle, at which it is attached.

Press 



Start the machine.

Press 

Wait reading to stabilize.



Press 

Confirm reading is accepted.



**Stop the machine.**

Now one needs to decide whether to keep or remove the trial weight from Plane #1.

E.g. trial weight can remain attached if vibration levels decreased.

Chose option and press .

Device displays calculated correction weight to be attached to eliminate disbalance.



Residual vibration can be measured now.

**Start the machine.**

Press .

Wait reading to stabilize.

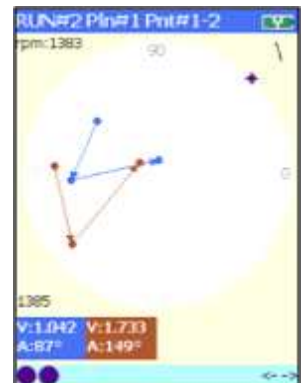

Confirm reading is accepted.

Press .

**Stop the machine.**



Device displays calculated trim weight to be attached to further eliminate disbalance.

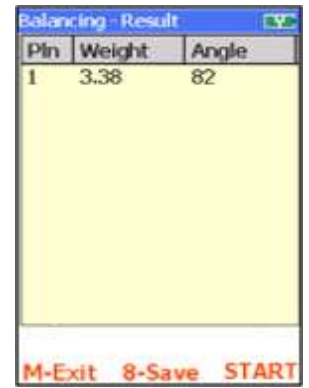

Pin	Weight	Angle
1	3.38	82

M-Exit 8-Save START

## USING OPTIONAL ACCESSORIES

### Stroboscope



### Eddy Current Probe

Connect the Eddy Current Probe via the Input adapter.



Set 701TXV input to Charge mode, Acceleration,  $m/c^2$ .

Set the 701TXV Sensor sensitivity as per equation:

Sens, pC = (Input Adapter capacitance, nF) x (Eddy Current Probe sensitivity, mV/ $\mu$ M).

\* 2000pF = 2nF.

e.g. (2nF) x (8mV/ $\mu$ M) = 16, so the 701TXV Sensor sensitivity should be set to 16pC, thus 701TXV will display readings in  $\mu$ M.

## FIRMWARE UPGRADE

### Firmware Upgrade using pen drive

Make sure that device battery is fully charged!



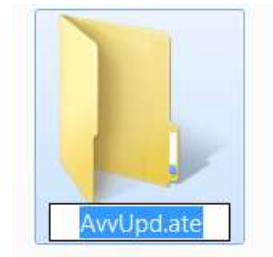

1. Insert USB thumb drive into PC/Laptop port. In the root directory of USB thumb drive – create the folder **AvvUpd.ate**



2. Copy firmware file **Avv711Intall.cab** to this folder



3. Remove USB thumb drive from PC/Laptop port and insert it to the qb701 USB host port. Press and hold  key for ~2 sec to turn qb701 on.



4. Invoke firmware updater by pressing     keys simultaneously.

5. Press  to confirm search for USB



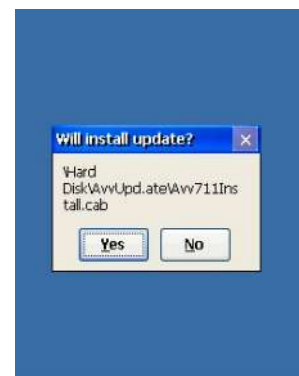

6. Press  to confirm start of firmware upgrade.



7. Press  key then  to confirm replace of all existing files



8. Press  key to choose NO, then press 



9. Firmware upgrade will run. Once finished press  to turn device OFF



## Firmware Upgrade Using Windows Mobile Device Center

**Make sure that device battery is fully charged!**

1. Connect AVV-711 to PC via USB cable. Press and hold  key for ~2 sec to turn qb701 on. Windows Mobile Device center will launch. Connect to qb701 and browse to the folder

“Storage Card/LaserAlignment/AvvUpd.ate/”

and paste there the firmware file

**Avv711Install.cab**



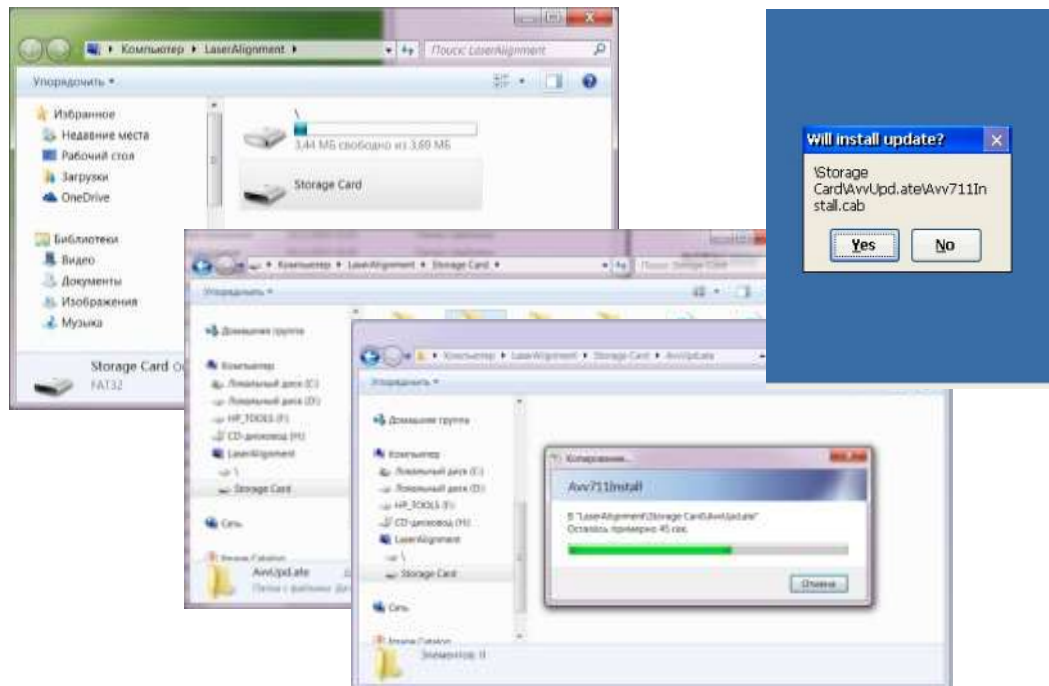

2. Wait until file copied.





3. Invoke firmware updaters by pressing     keys simultaneously.

4. Press  to confirm start of firmware upgrade.

5. Press  key then  to confirm  
replace of all existing files



6. Press  key to choose NO, then  
press 



7. Firmware upgrade will run. Once  
finished press  to turn device  
OFF



## LASER ALIGNMENT SYSTEM. GENERAL

### Safety Precautions

Be sure the machines to be measured, cannot be started unintentionally as this can cause injuries. For this purpose, before the mounting of equipment, either block the power switch in the “Off” position or remove the safety fuses. These precautionary rules must be followed until the measuring system is dismantled from the measured machine.

### Laser Safety Precautions

The KOHTECT qb701 alignment system is the class II laser device at typical wavelength of 650nm, delivered output power of less than 1 mW and maximum radiant energy per pulse of 0.1 mJ. The Class II laser comply with requirement outlined by USA’s FDA as well as international ANSI, BS 4803 and IEC 825 standard. Be sure to follow the following safety precautions to avoid personal injuries and damage to the system

- ⚠ **Do not look directly into the laser beam at any time!**
- ⚠ **Do not direct laser beam on to the people’s eyes!**



### ATTENTION!

Do not expose qb701 parts to heavy impacts, high humidity and extreme temperature.

Do not try open / dismantle measuring units and the display unit – this can damage the system, and your after-sales service warranty will come void.

### INJURY RESPONSIBILITY DISCLAIMER

Neither the NPP KOHTECT enterprise nor our authorized dealers are liable for the damages caused to machinery or equipment by use of the qb701 system. We carefully check text of this manual to eliminate errors, nonetheless there may be mistakes or inaccuracy involved. We will be grateful for your reporting to us about any error, and we will be able to correct them in the subsequent editions of the manual.

## TECHNICAL DESCRIPTION

### Designation

**qb701** alignment system (further as System) is designed for measurement of shaft axis misalignment of coupled machines, and calculation of movable machine adjustment required to eliminate misalignment that exceeds permissible tolerances;

The machine alignment means adjustment of the relative position of two coupled machines (e.g. motor and pump) so that the center line of the axis will be concentric when the machines are running under normal working conditions.

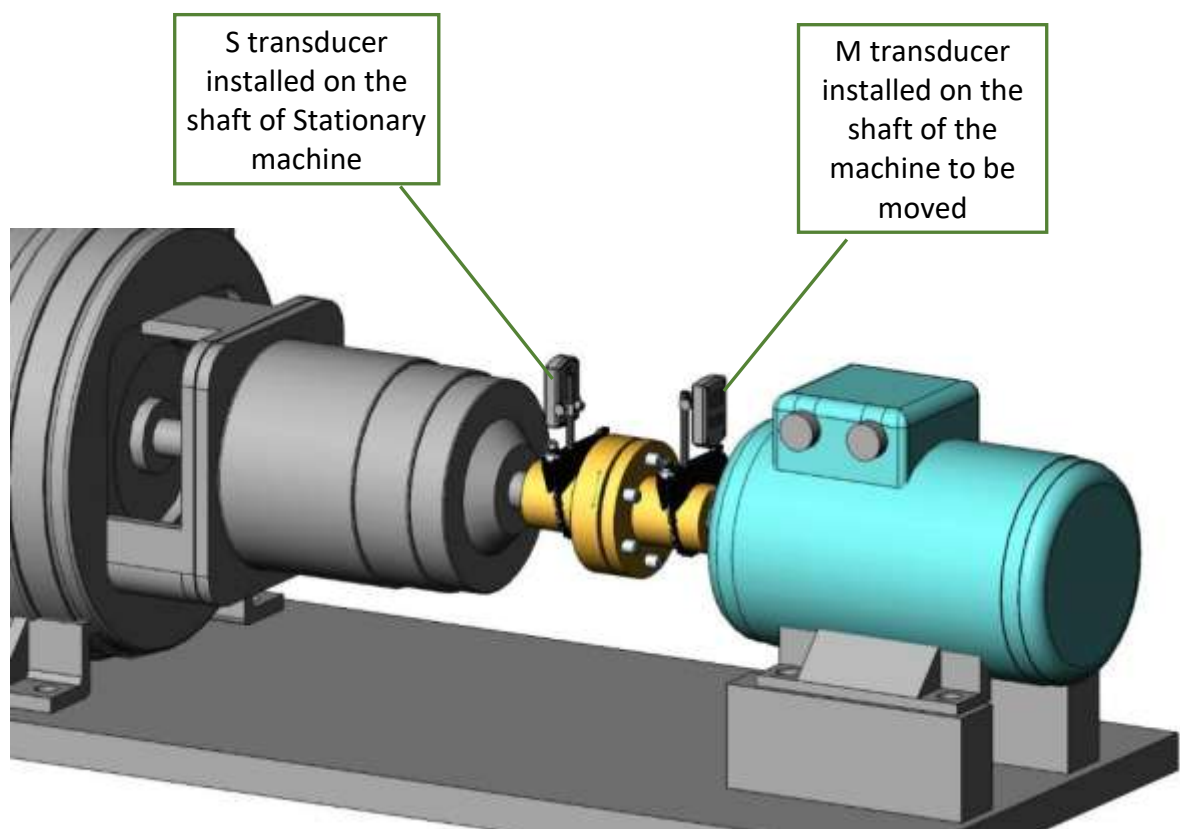

## Misalignment Parameters

Misalignment of any rotating machine is expressed in parallel (Offset) and angular (Gap) of the shafts. Most frequently in practice, both of them are present simultaneously. Different kinds of misalignment of axes are shown in Fig. 2.



	Parallel misalignment of axes – Offset (displacement)
	Angular misalignment of axes – Gap
	Parallel and angular misalignment of axes – (Offset + Gap)

Fig 2

The parallel (Offset) and angular (Gap) misalignment of axes is determined in two mutually perpendicular planes. For the purpose of elimination of the parallel and angular misalignment of axes, in each of the planes a correction of position of the movable machine (M) will be done.

For the horizontal mounted machine – the movable machine (M) position is adjusted in the horizontal and vertical planes.

For the vertical mounted machine, operator determines arrangement of the correction planes, basing on considerations of the convenience and technological effectiveness of moving of the movable (M) machine.

*Stationary machine (S) - in the process of eliminating of the axes misalignment the position of this machine stay static, i.e. it does not move.*

*Movable machine (M) – the machine, which position is adjusted for eliminating of the parallel and angular misalignment of axes.*

The measurement system calculates the values of the angular and parallel misalignment of axes in the plane of the coupling (in two mutually perpendicular planes), and the adjustment values for the machine feet on the movable (M) machine, that is necessary for elimination of this misalignment of axes. Fig. 3 shows misalignment of axes and the values for its correction just for vertical plane.

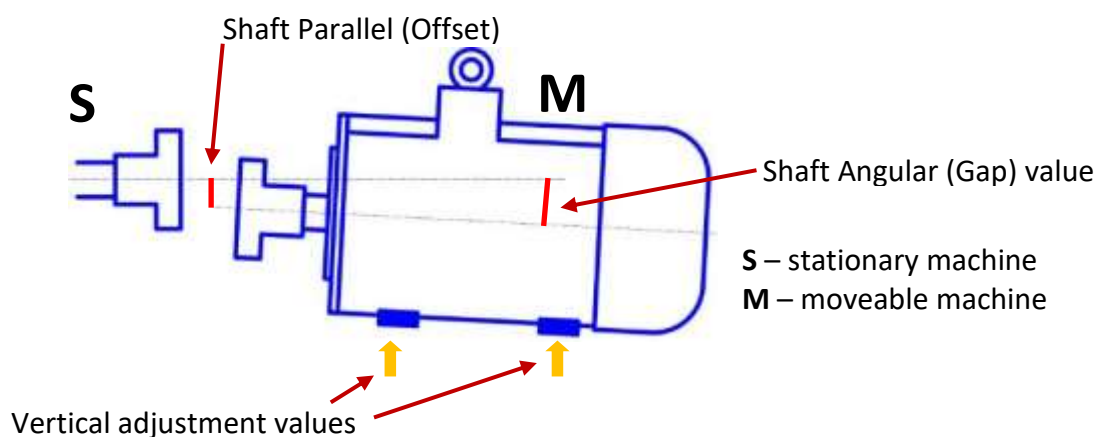

## Specification and Features

- Separation distance between measuring transducer units, up to 10 m
- Display unit operating temperature range, -10..+55 degree C
- Display unit and transducer's ingress protection level – IP65
- Measurement accuracy, 1%+0.01
- Laser type: Visible red 635-670 nm, <1 mW
- Detector type: CCD, length 30 mm
- Display resolution, 0.01 or 0.001 mm, (1 or 0.1 mil )
- Measuring resolution, 0.001mm
- Electronic inclinometer resolution, 0.1 degree
- Display unit battery: Rechargeable Li-Ion battery, 10hrs to recharge
- Transducers battery: Rechargeable Li-Po battery, 12hrs to recharge
- Gross weight, incl. carry case 3.9 kg
- Built-in application programs and options:
  - o horizontal shaft alignment at any shaft position, from 60°, up to 360°, up to 36 readings can be measured; auto sweep mode can be used;
  - o vertical (flange machine) shaft alignment;
  - o editable misalignment tolerances;
  - o setup options;
  - o soft foot;
  - o thermal growth;
  - o shimming simulator to calculate for expected residual misalignment;

## System Package

The System includes (Fig. 1):

1. Display unit
2. Measuring transducer units – S, M
3. universal V-brackets for transducers mounting, chains for 15...250mm shafts, extension chains for shafts up to 500mm diameter, rods 100mm x2, 150mm x2, stackable, allen key x2
4. measuring tape, 3m
5. 120...240 Volts AC charger
6. USB PC communication cable
7. Operating instructions manual and ConSpect freeware on the internal drive of display unit
8. Carrying case with form-inserted



## System overview



## Mounting Transducers

- Firmly tighten rods 1 into the shaft brackets 2.
- Put thumb nut 3 into the bracket 2, then hook the chain 5 on the stud 4.
- Firmly tighten the thumb nut 3. Shaft brackets with rods must be mounted at the same angular position.
- Mount transducers on the rods. Always try to mount transducers at minimal possible radial height. Make sure that transducers are not touching brackets or machine parts.

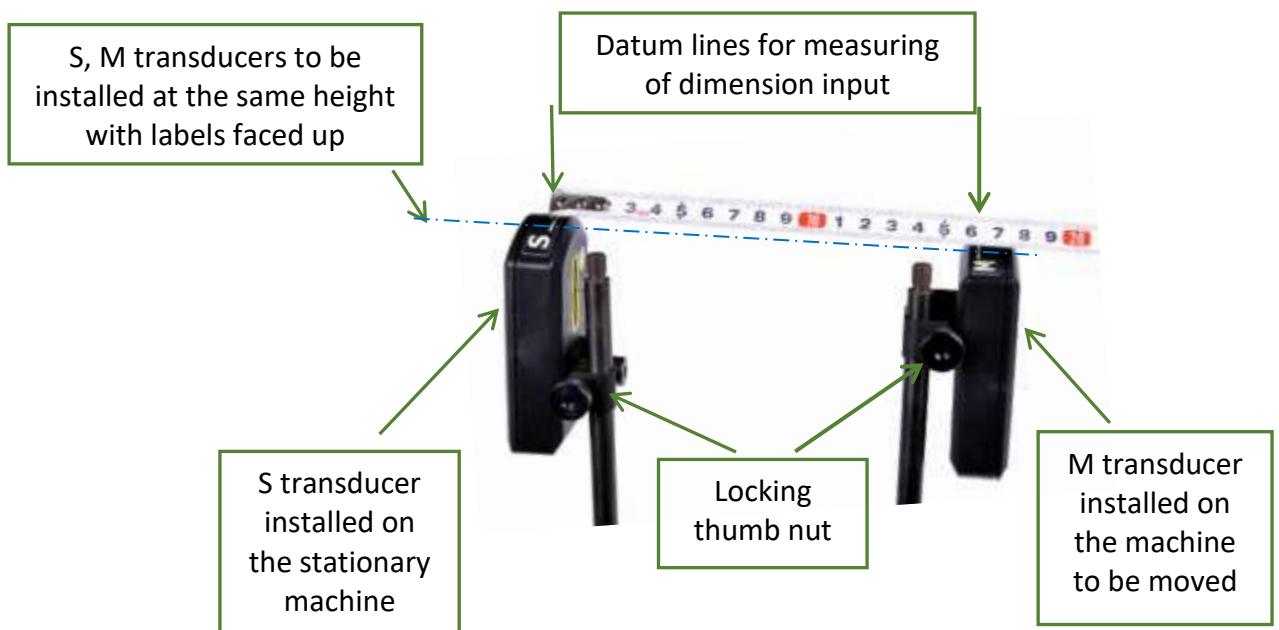
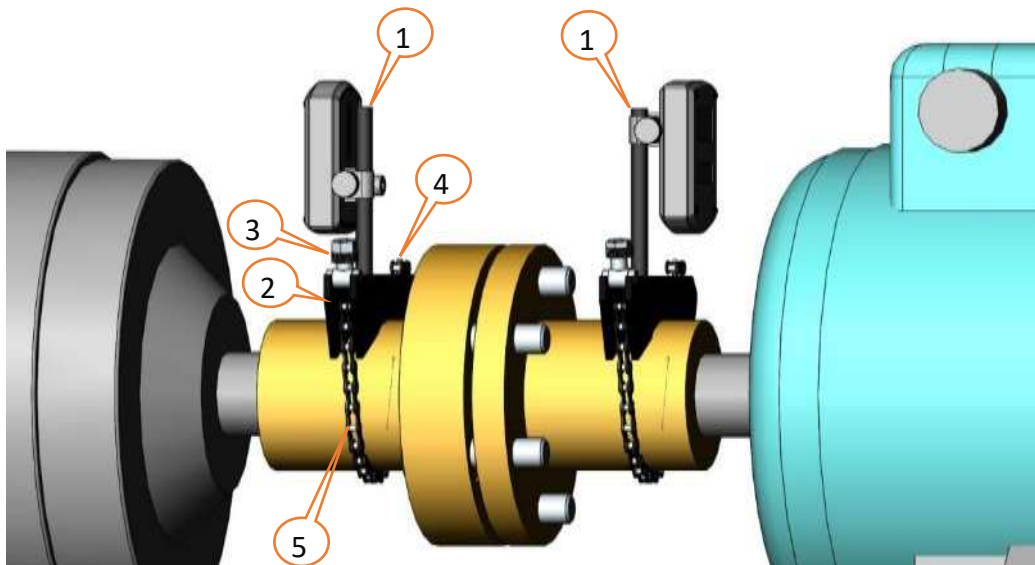

## Laser Beam Adjustment

- Loosen thumb nut and horizontally adjust transducer so the middle of the laser line is at the transducer's window.
- Slightly tighten thumb nut then vertically adjust laser line to the center of the transducer's window.
- Firmly tighten the thumb nut.
- Adjust second transducer in the same way.

**Use an angular adjustment only. Do not change transducers installation height!**

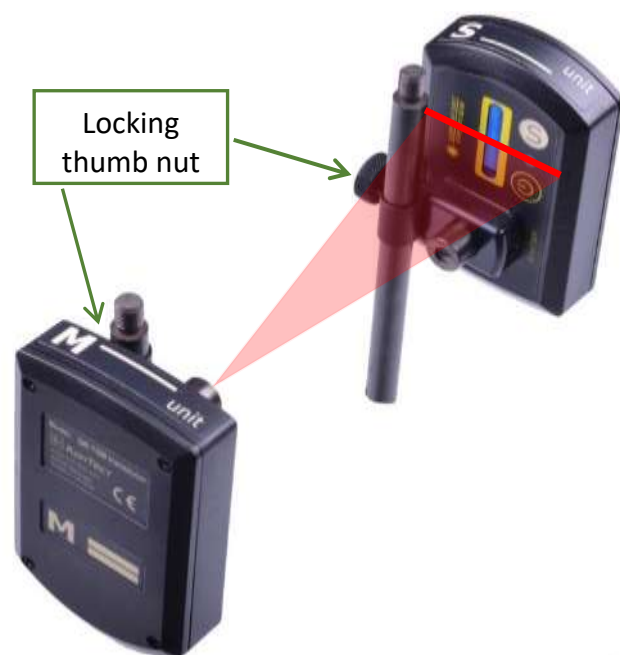



## GETTING STARTED

### Common control keys consideration

To turn ON/OFF display unit and transducers – press and hold the power button  for ~2 sec.

In case the system hangs and device did not respond to any keys - press and hold the power button  for ~10 sec, the system will be reset.

To close any currently active window, without saving, except main menu of the device, press  button (it serves as escape key).

The  button in most cases causes applying (saving) changes (invoke selection) and exit (from edit box; or from current window, except such windows as collect data, aligning, soft foot and so on where it is not applicable).

To invoke menu item – move cursor to this item and press  key, or just press the shortcut key regardless of the cursor position. In most cases the shortcut key is depicted left to the menu item.

### Auto save

All procedures are designed with auto save. For temporarily shut down your current work press  until program exits to main menu of the device. Data saved now and device can be turned off.

### Device setup

To invoke Setup menu – move cursor to Setup

icon and press  button, or press  key.

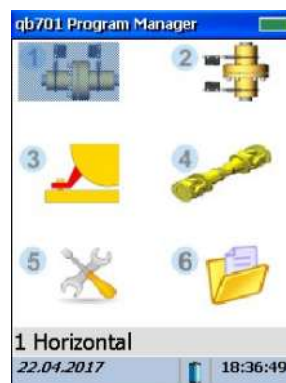

# Setup Menu Items



– to setup date and time

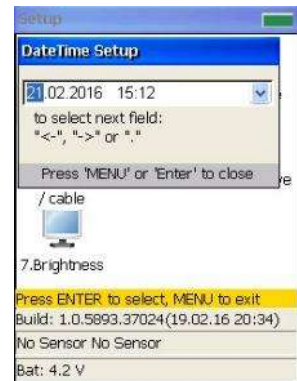

– to set device auto off delay in seconds. When set to 0 – auto off is disabled.

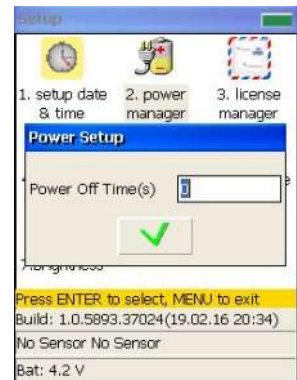

– to install license file which enables measurement functions. Press 9, browse to the license file, press Enter to open and install licenses.



+ Function enabled, valid until

Serial number



– to switch between wireless/cable transducers connection. For wireless connection – press 1 or 2 to enter number of transducers to be connected

Number of transducers to





5. language

– to choose user interface language

Use keys to choose language, then press



6. USB drive

– to switch qb701 into USB

storage device mode. By

device can be connected to the PC via Windows Mobile Device Center. USB mass device mode can be used as alternative.



mass  
default  
Microsoft  
storage



7. Brightness

– to adjust the display backlight brightness

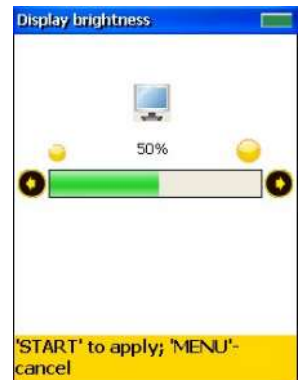

8. Preferen...

– to choose default alignment or 2-D biaxial mode. In biaxial mode horizontal and vertical machine aligning data update could be made at a static transducers position (e.g. 3 h). For QB-transducers the only available mode is

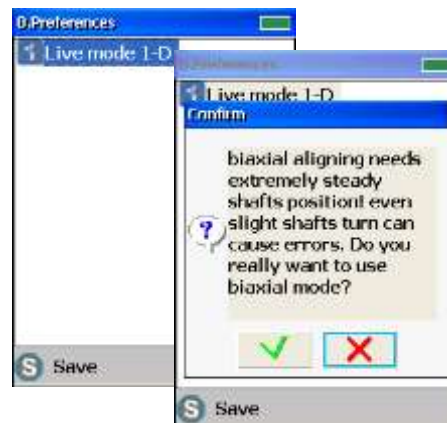

mode 1-D  
both  
with live  
TSM  
1-D.

## HORIZONTAL MACHINE ALIGNMENT

### Short Explanation

- Mount transducers on shafts
- Run Horizontal program
- Enter dimensions
- Set parameters. E.g. Measurement mode – clock type (9-12-3 o'clock positions)
- Turn shafts with transducers at first position 9 o'clock (90°). Press Start to take readings
- Turn shafts with transducers at second position 12 o'clock (180°). Press Start to take readings
- Turn shafts with transducers at last position 3 o'clock (270°). Press Start to take readings
- After that device will calculate misalignment and displays required corrections for Movable machine

### Transducer's Positions Conventions

While taking measurements, it is necessary to follow conventions for transducers positions on the shafts with the S and M measuring transducers with regard to the relative position of the S and M machines as depicted on the figure.

Angular positions in degrees adopted in the device are as follows:

6 o'clock - 0°

9 o'clock - 90°

12 o'clock - 180°

3 o'clock - 270°

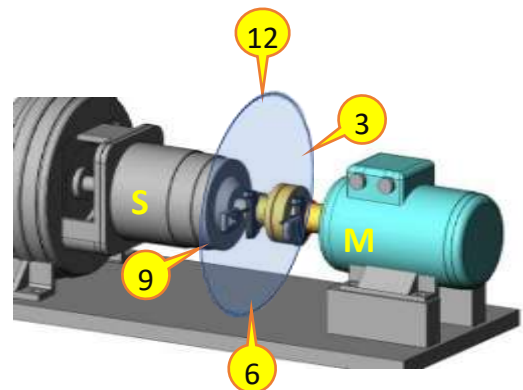

## Parameters

In Main Menu run **Horizontal** program.

Choose **New Task**.

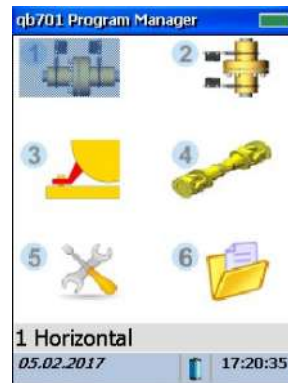

Machine dimensions / measurement setup screen

Press  key to start editing of the dimensions values

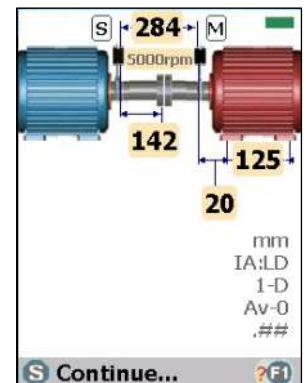

Press  key for parameters/key legend:

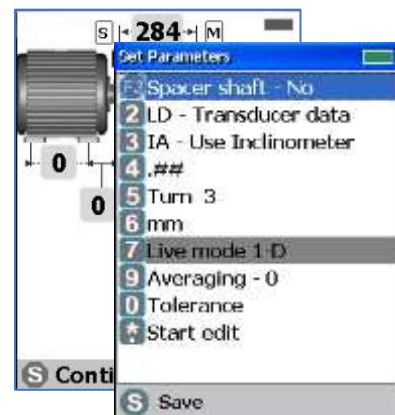

Press  - to toggle Spacer shaft Yes/No

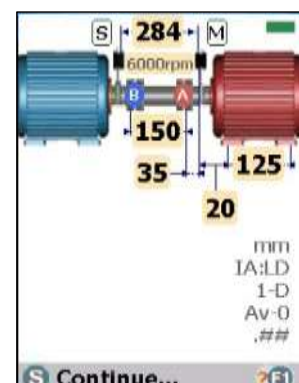
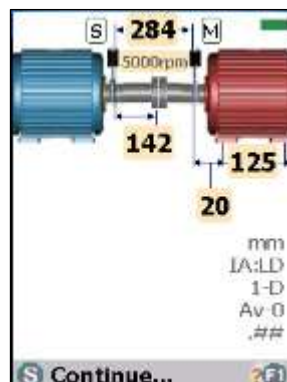

Press  - to toggle data input – **LD** transducer's data / **MD** – manual data

Press  - to toggle angle input – **IA** use inclinometer / **MA** manual angle. Manual angle input used for vertical machines, when electronic inclinometer cannot be used.

Press  - to toggle displayed precision – 2 or 3 digit.

Press  then  - to toggle measurement mode:

**Turn 3** - clock mode **9-12-3 o'clock** – readings to be taken at three predefined shaft positions – 9 o'clock, then 12 o'clock, then 3 o'clock. After that, device will proceed to the result screen.

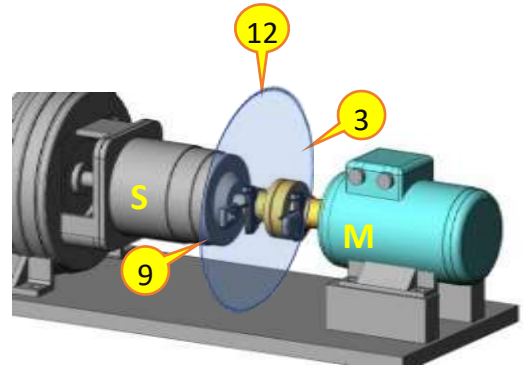

**Turn 4** points – readings to be taken at four predefined shaft positions separated by 90° or 45° (3hr / 1:30hr). After that the device will proceed to the result screen.

**Multipoint** mode – measurements may be taken at any of minimum 3 up to 36 positions. After taking enough readings one should press  to proceed to the result screen.

## Tolerance Setup

Press  to enter tolerance setup menu.

Press  to use predefined RPM/tolerance table

Press  to enter user defined tolerance values

Press  to save changes,  to discard changes.

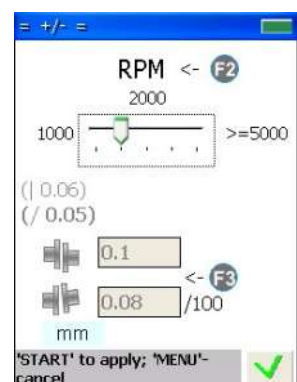

## Taking Measurements. Clock Mode

Press  to edit dimensions.

Set parameters and enter dimensions then press  key to proceed.

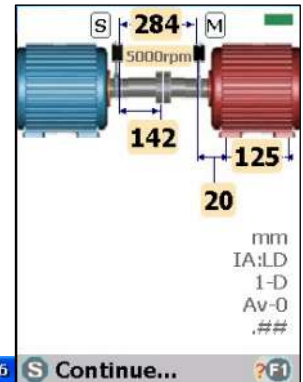

Turn shafts to first position – 9 o'clock (90°)

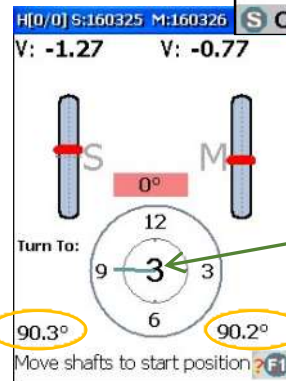
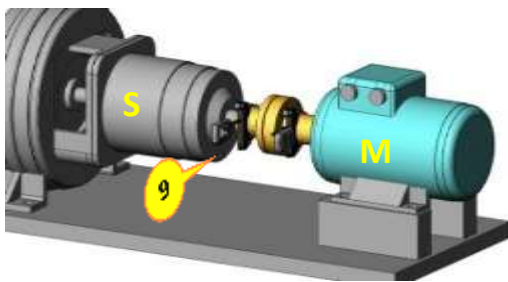

3 – clock mode  
\* – multipoint

Press  to take first reading.

First measurement

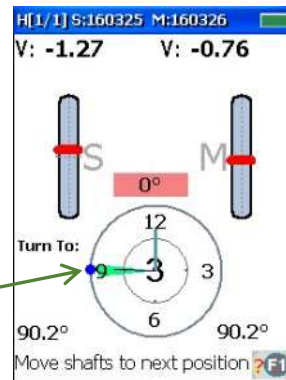

Turn shafts to second position – 12 o'clock (180°)

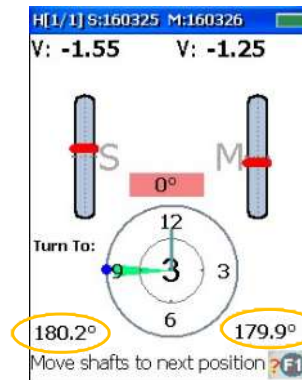
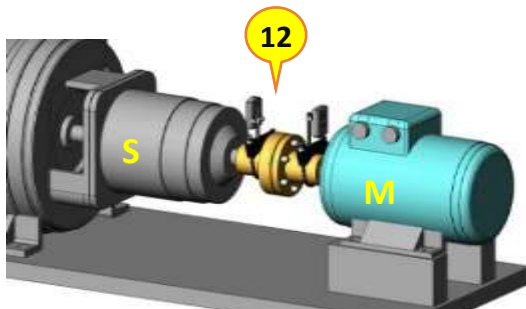

Press  to take second reading.

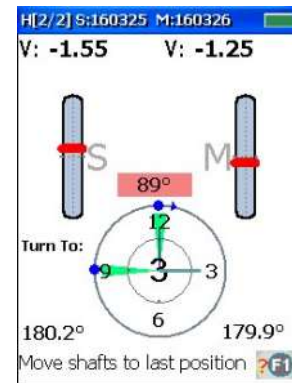

Turn shafts to third/last position – 3 o'clock (270°)

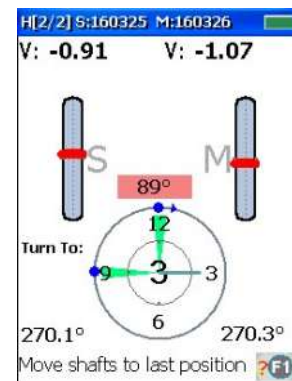
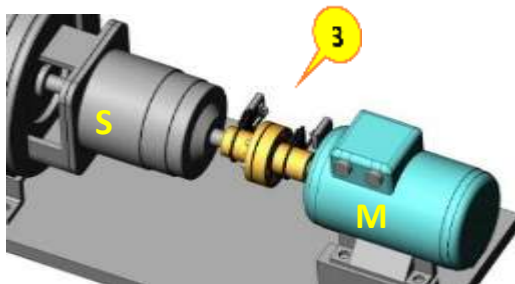

Press  to take third reading.

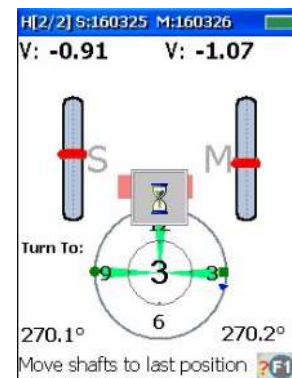

When three readings are taken device will proceed to the result screen.

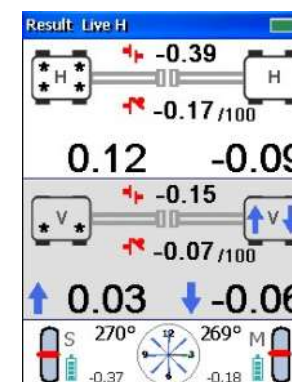

## Taking Measurements. Multipoint Mode

In multipoint mode readings can be collected at any shafts position minimum 3 up to 36 positions.

qb701 is able to calculate misalignment after collecting at least 3 points within as little as 70 degree range. **However always try to cover as wide shaft turn angle as possible.**

Press  to take reading, and then turn shafts to next position.

Yellow clock face means that point is already collected and shafts should be turned to next position.

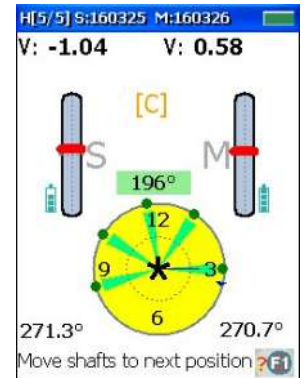
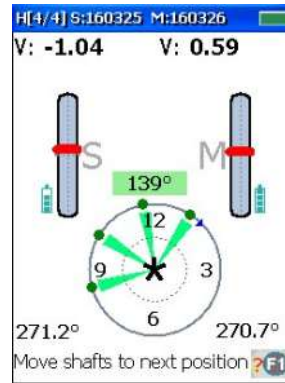

When enough readings are collected – press  to proceed to the result screen.

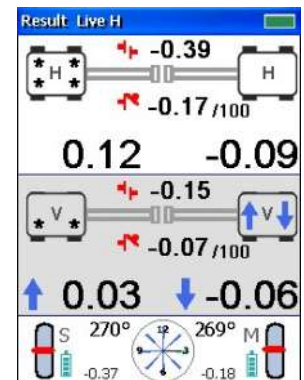

## Taking Readings. Auto Shooting mode

Turn shafts to first position, then press  to activate auto shooting mode.

Auto shooting mode is active

When auto shooting mode is active – device waits for stable shaft position then automatically records data and prompts to move shafts to the next position.

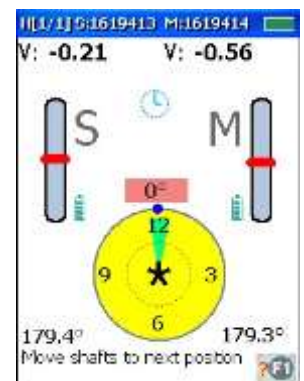
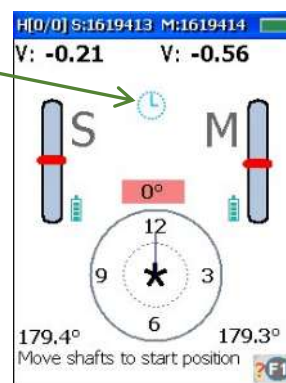

Auto shooting mode can be activated in both Clock mode and Multipoint mode.

When device is in Multipoint mode and enough readings are collected – press **F5** to proceed to the result screen.

When device is in Clock mode and three/four readings are taken device will automatically proceed to the result screen.

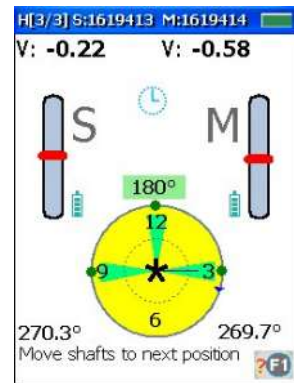

### Readings quality assessment

While taking readings device performs assessment of data quality based on standard deviation. Quality is indicated by color of dots at measurement positions:

Blue – assessment is impossible (too few points collected)

Green – good quality

Yellow – acceptable quality

Red – poor quality, must be re-measured.

The factors which may affect readings – high vibration, partial clipping of the laser beam, mechanical looseness, accidental alteration of transducers position (e.g. by touching it).

Readings quality assessment is useful option which helps to detect such conditions.

### Editing of measurement points

It is possible to edit collected data when poor quality data is detected.

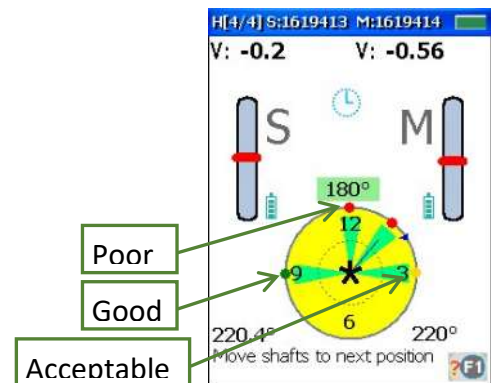

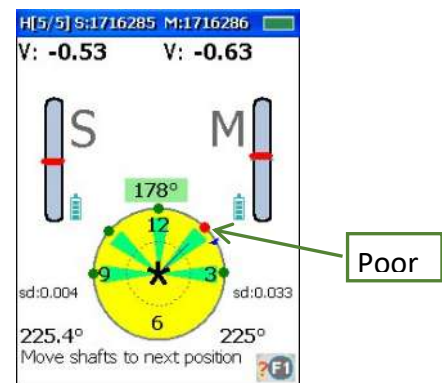

### Editing of measurement points

It is possible to edit collected data when poor quality data is detected.





Press  key to activate edit mode

Use   keys to scroll over collected readings

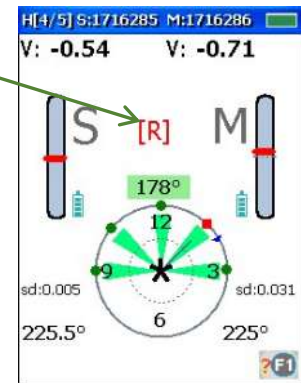
Edit mode



Use  to delete readings

Use  key to quit edit mode (press until cursor points to the last measurement, then quit)

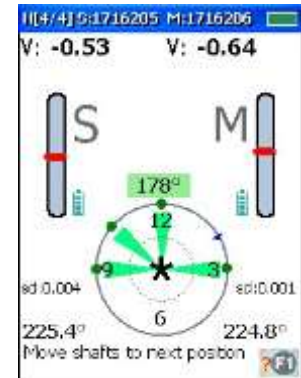
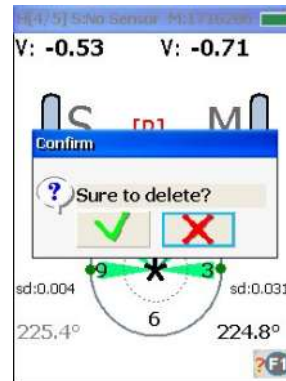

## Result Screen

On the result screen device displays parallel and angular misalignment at the coupling and values of the required corrections in horizontal and vertical directions for movable machine. Blue arrows clearly displays directions in which movable machine must be moved to eliminate misalignment.

Parallel and angular misalignment at the coupling

Values and directions of adjustment for Front and Rear feet

Horizontal adjustment: Top view at the Movable machine

Vertical adjustment: Side view at the Movable machine

## Movable machine Adjustment

To make adjustment in **vertical** direction transducers must be turned to 6 or 12 o'clock ( $0^\circ$  or  $180^\circ$ ) position.

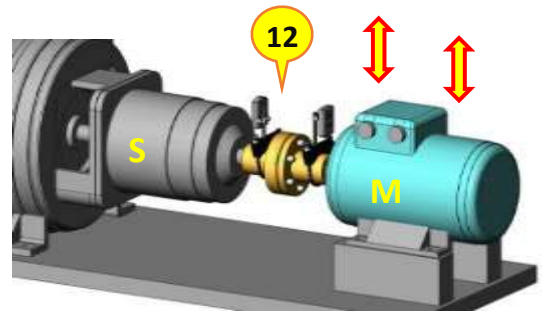

To make adjustment in **horizontal** direction transducers must be turned to 9 or 3 o'clock ( $90^\circ$  or  $270^\circ$ ) position.

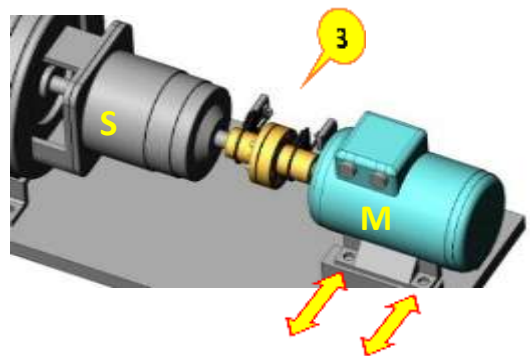

Device may reduce number of available transducers positions for machine adjustment.

Permissible transducer positions are indicated at the clock face. Only permissible transducer positions can be used for machine adjustment.

Transducers now at 3 o'clock ( $270^\circ$ ) live data for H direction

Data for V direction are frozen (display shaded) until transducers are not turned to 12 or 6 o'clock



Permissible transducer positions –  
**12, 6** – for V direction  
**3** – for H direction

## Machines with Spacer Shaft

Press **F3** to activate Spacer Shaft option.

Procedure and options are the same as for Horizontal program.

Enter machine dimensions.

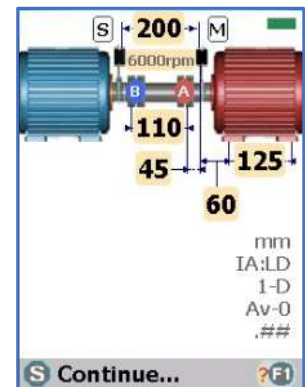

Collect readings.

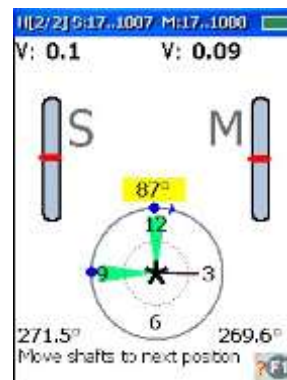
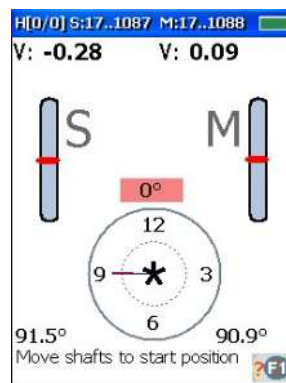

Make moveable machine correction.

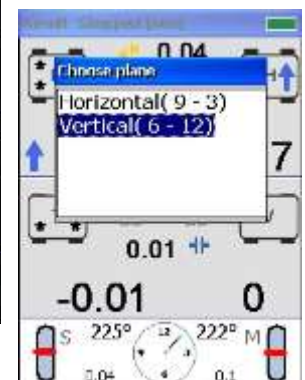
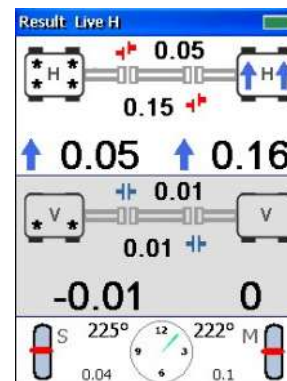

## Lock Feet Pair

In some cases could be practical to swap movable machine. This function is applicable for Machines with and without Spacer shaft.

Press  key. Device will prompt to enter missed dimensions.

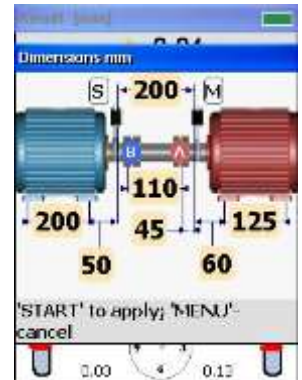
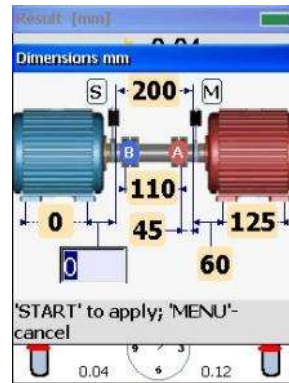

Press  key to lock feet pair.



Press  to apply.



Machine to be moved

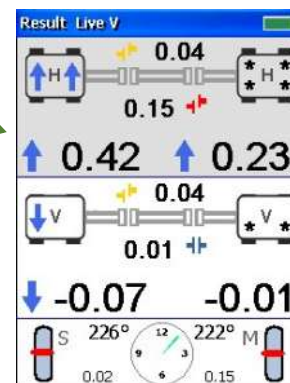

Static Machin

## Report file saving

Report file can be saved at any stage of alignment

To save report file – press  key in the result screen

Reports can be saved to internal SD card or to thumb drive connected to USB host socket of the AVV-711 display unit

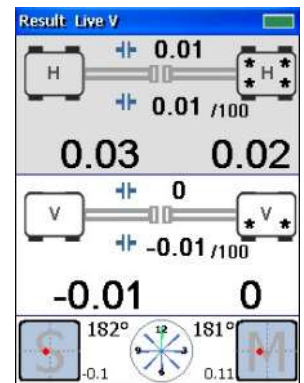

Use  key to choose drive

Use       keys to browse folders



Use  to open folder

Use  to move one level up

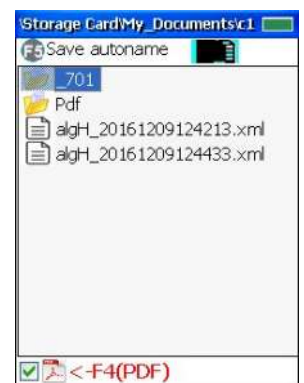

Use  to create new folder

Use  to turn on/off PDF reports generation

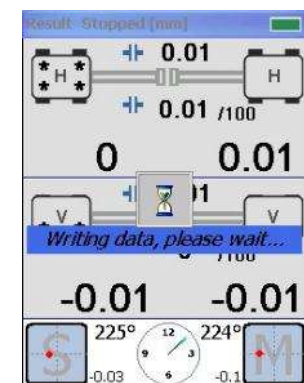

Press  or  key to save report with default name



Press  to edit file name, then press  to save file



## SOFT FOOT

Soft foot condition makes impossible proper machine alignment. So it should be eliminated prior to conduct alignment work. Soft Foot program intended for this purpose.

In Main Menu run **Soft Foot** program.

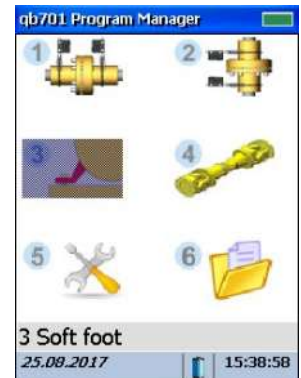

Enter distances

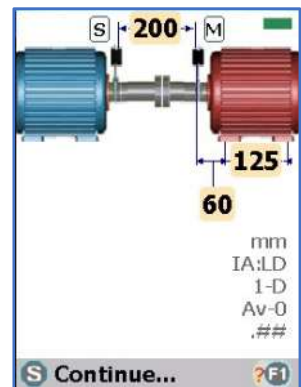

Make sure that all foots are tightened.

Turn shafts with transducers at 12 o'clock position.

Press  key to proceed.

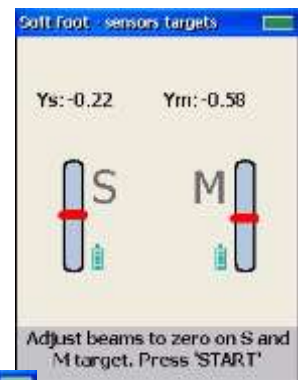
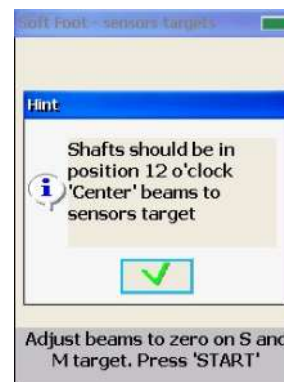

- Loosen first bolt fully
- Wait about 5 sec
- Press  key
- Tighten bolt firmly
- Press  key
- Loosen second bolt fully

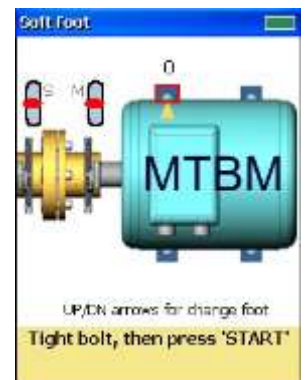
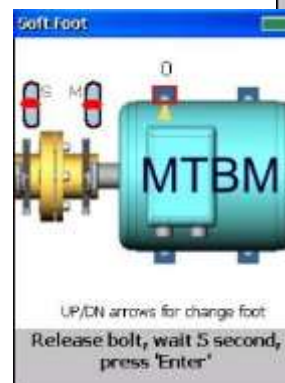

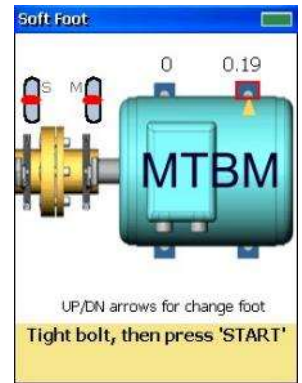
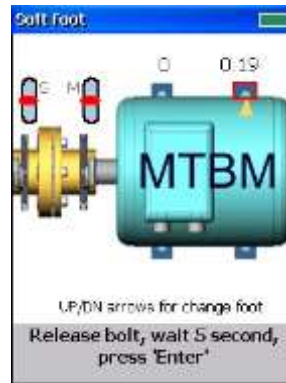

- Wait about 5 sec
- Press  key
- Tighten bolt firmly
- Press  key

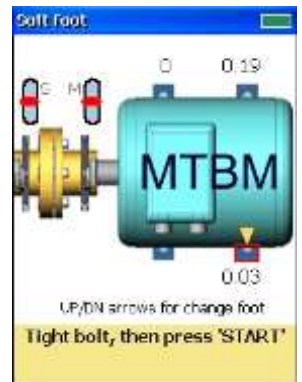
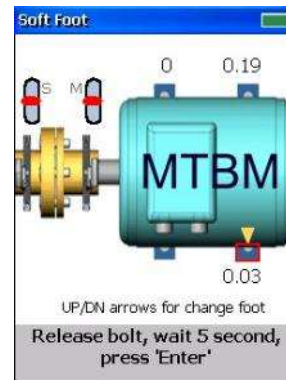

- Loosen third bolt fully
- Wait about 5 sec
- Press  key
- Tighten bolt firmly
- Press  key



- Loosen fourth bolt fully
- Wait about 5 sec
- Press  key
- Tighten bolt firmly
- Press  key

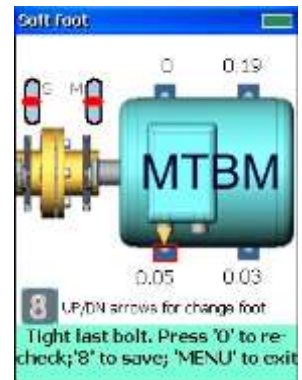
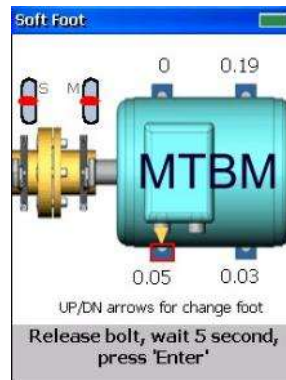

Bolt selection sequence can be changed by manually selecting the bolt by arrow keys.

# VERTICAL MACHINE ALIGNMENT

## Short Explanation

- Mount transducers on shafts
- Run Vertical program
- Mark on the machine three positions spaced by 90° (9-12-3 o'clock positions)
- Enter dimensions
- Set parameters. E.g. Tolerances.
- Turn shafts with transducers at first position 9 o'clock (90°). Press Start to take readings
- Turn shafts with transducers at second position 12 o'clock (180°). Press Start to take readings
- Turn shafts with transducers at last position 3 o'clock (270°). Press Start to take readings

After that device will calculate misalignment and displays required corrections for Movable machine

## Transducer's Positions Conventions

While taking measurements, it is necessary to follow conventions for transducers positions on the shafts with the S and M measuring transducers with regard to the relative position of the S and M machines as depicted on the figure.

Angular positions in degrees adopted in the device are as follows:

6 o'clock - 0°

9 o'clock - 90°

12 o'clock - 180°

3 o'clock - 270°

The electronic inclinometers cannot be used on the vertical machines, so "Manual angle" is set by default. One should mark measurement positions on the machine prior to start measuring.

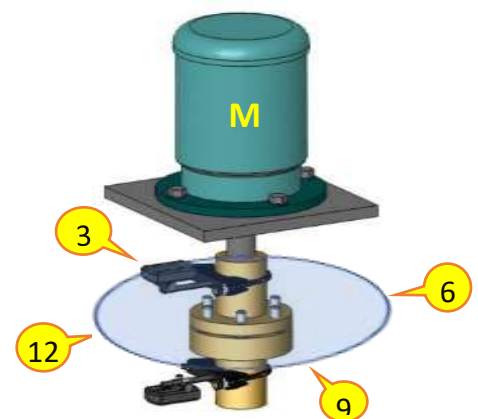

## Parameters

In Main Menu run **Vertical** program.

Choose **New Task**.

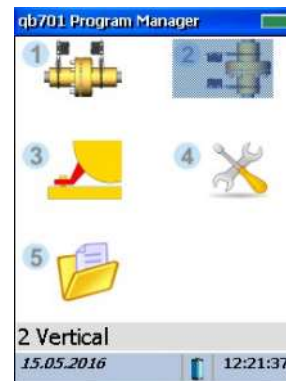

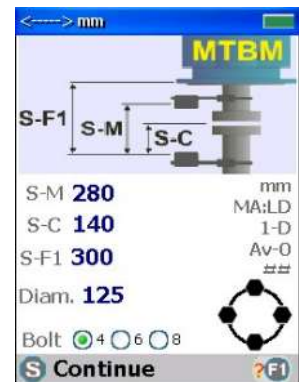

Machine dimensions / measurement setup screen

Press  key to edit dimensions values



Press  key for parameters/key legend:

Press  - to toggle data input – LD transducer's data / MD – manual data

Press  - to toggle angle input – IA use inclinometer / MA manual angle. Manual angle input used for vertical machines, since electronic inclinometer cannot be used.

Press  - to toggle displayed precision – 2 or 3 digits.

Press  - to toggle measurement mode: Clock mode **9-12-3 o'clock** – readings to be taken at three predefined shaft positions – 9 o'clock, then 12 o'clock, then 3 o'clock. Device will proceed to the result screen then.

Press  to switch displayed units mm/inch

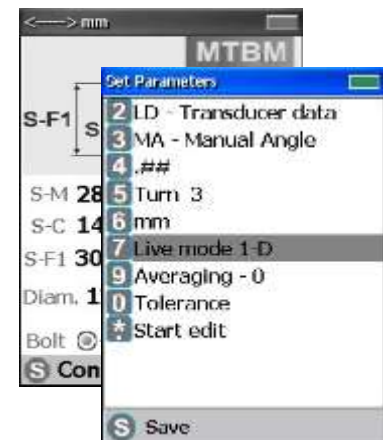

**Multipoint** mode – measurements may be taken at any minimum 3 up to 36 positions. After taking enough readings one should press **F5** to proceed to the result screen. For Vertical machines inclinometer data is unavailable, so angle value for each point should be entered manually, taking into account mentioned above positions conventions.

Press **DELETE** to enter tolerance setup menu.

Press **F2** to use predefined RPM/tolerance table

Press **F3** to enter user defined tolerance values

Press **START** to save changes, **MENU** to discard changes.

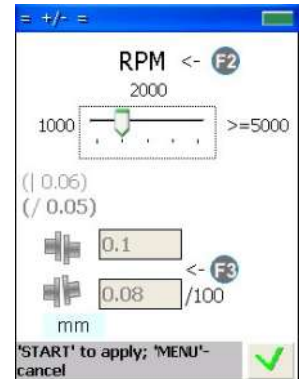

## Taking Measurements. Clock Mode

Press **\*** to edit dimensions.

Mark on the machine measurement positions separated by 90° (or 45°)

Set parameters and enter dimensions then press **START** key to proceed.

Turn shafts to first position – 9 o'clock (90°)



Press **START** to take first reading.

Arrow keys **↑** **↓** can be used to choose actual measurement position

Turn shafts to second position – 12 o'clock (180°)

Press  to take second reading.

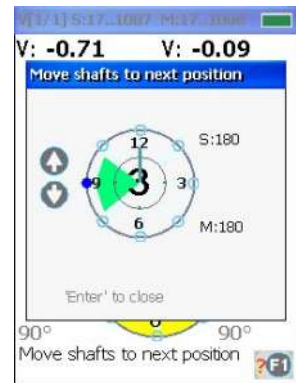

Turn shafts to third/last position – 3 o'clock (270°)

Press  to take third reading.

Measurement position selection window can be closed by  key.

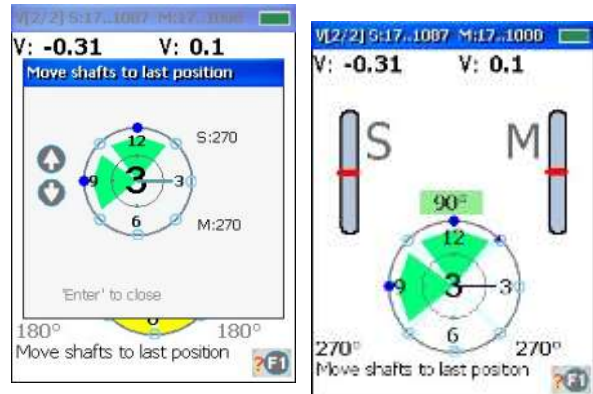

When three readings are taken device will proceed to the result screen.

### Result Screen

At this moment transducers are at 3 o'clock (270°) position – so device displays live updated values for 9-3 direction.

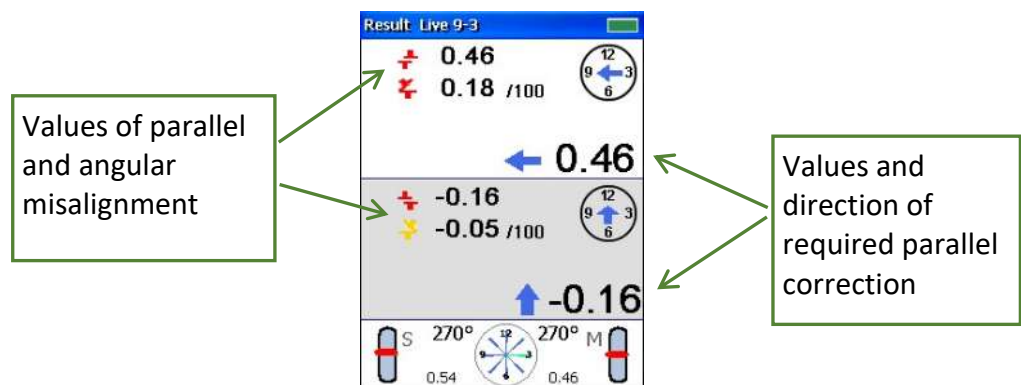

Blue arrows are displaying directions in which movable machine must be moved to eliminate parallel misalignment.

Keys legend can be invoked by  key

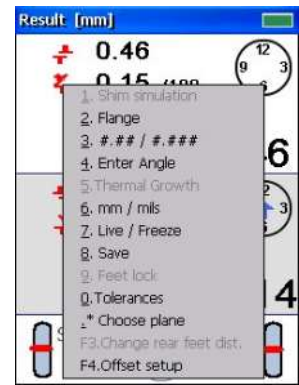

Press  key to toggle between parallel/shimming values screens.

Shimming values

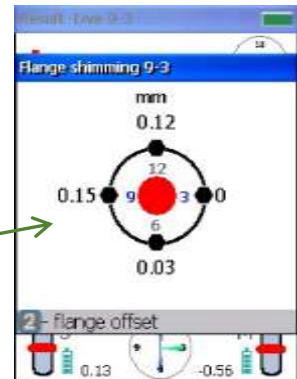



Press  key to choose plane (9-3 or 12-6) in which parallel correction will be performed.

To make correction in 9-3 plane transducers must be placed at 9 or 3 o'clock position.

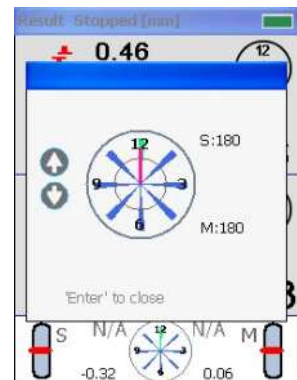
To make correction in 12-6 plane transducers must be placed at 12 or 6 o'clock position.





Use arrows keys   to choose position at which transducers will be placed.

Turn shafts to place transducers in this position then press  key.

## Machine Correction @45

To avoid additional shaft rotation when changing the correction plane (Horizontal / Vertical or 12-6 / 9-3), the transducers are rotated together with the shafts to any 45° positions: 10:30, 1:30, 4:30, 7:30 o'clock. This option can be used on Horizontal and Vertical machines.

Use arrows keys   to choose position at which transducers will be placed, then press  key.

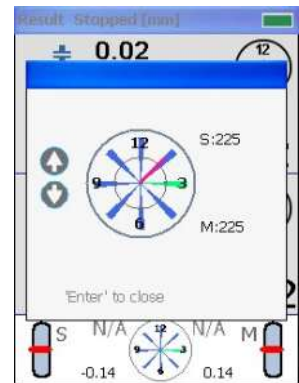

Live alignment at 12-6 plane.

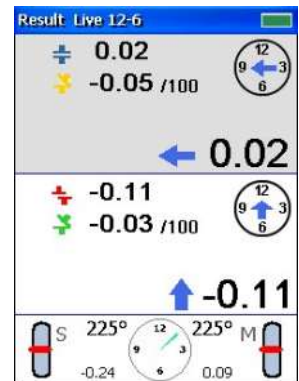

Press  key to choose 9-3 plane.

There is no need to turn shafts in this mode.

Transducers can be at static 45° position.

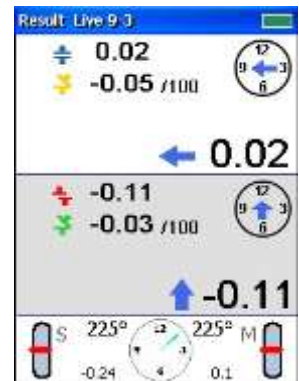
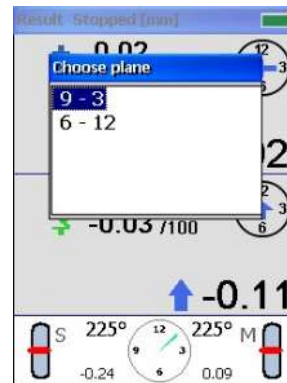

The coupling symbol color reflects the current misalignment level. **Green** indicates that the residual misalignment is within tolerance, and **black** represents a perfect result.

Stop the correction process as soon as the residual misalignment is within tolerance – there is no need to aim for zero.

## Charging batteries

The battery can be charged by means of USB type AC charger or via PC/laptop USB port.

Immediately after connecting charger to the display unit there are few seconds to change charge current - press and hold ON button for ~2sec until LED changes flash rate.

Low flash rate – normal charge, high rate – fast charge. Keep in mind that PC/laptop USB port can only provide normal charge.

Charging will be terminated and the LED will turn off when battery is fully charged. No overcharge occurs in case the USB cable is left connected.



## Firmware Upgrade

Make sure that device battery is fully charged!

10. Insert USB thumb drive into PC/Laptop port. In the root directory of USB thumb drive – create the folder **AvvUpd.ate**

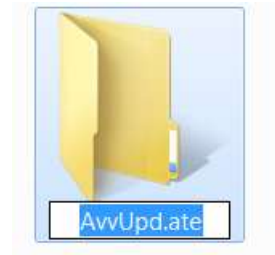



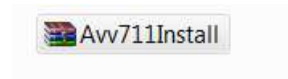

11. Copy firmware file **Avv711Intall.cab** to this folder



12. Remove USB thumb drive from PC/Laptop port and insert it to the qb701 USB host port.

Press and hold  key for ~2 sec to turn qb701 on.



13. Invoke firmware updater by pressing     keys simultaneously.

14. Press  to conform search for USB



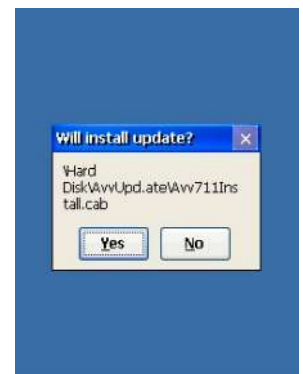

15. Press  to confirm start of firmware upgrade.



16. Press  key then  to confirm  
replace of all existing files



17. Press  key to choose NO, then  
press 



18. Firmware upgrade will run. Once  
finished press  to turn device  
OFF



## Firmware Upgrade Using Windows Mobile Device Center

**Make sure that device battery is fully charged!**

8. Connect AVV-711 to PC via USB cable. Press and hold  key for ~2 sec to turn qb701 on. Windows Mobile Device center will launch. Connect to qb701 and browse to the folder

“Storage Card/LaserAlignment/AvvUpd.ate/”

and paste there the firmware file

**Avv711Install.cab**



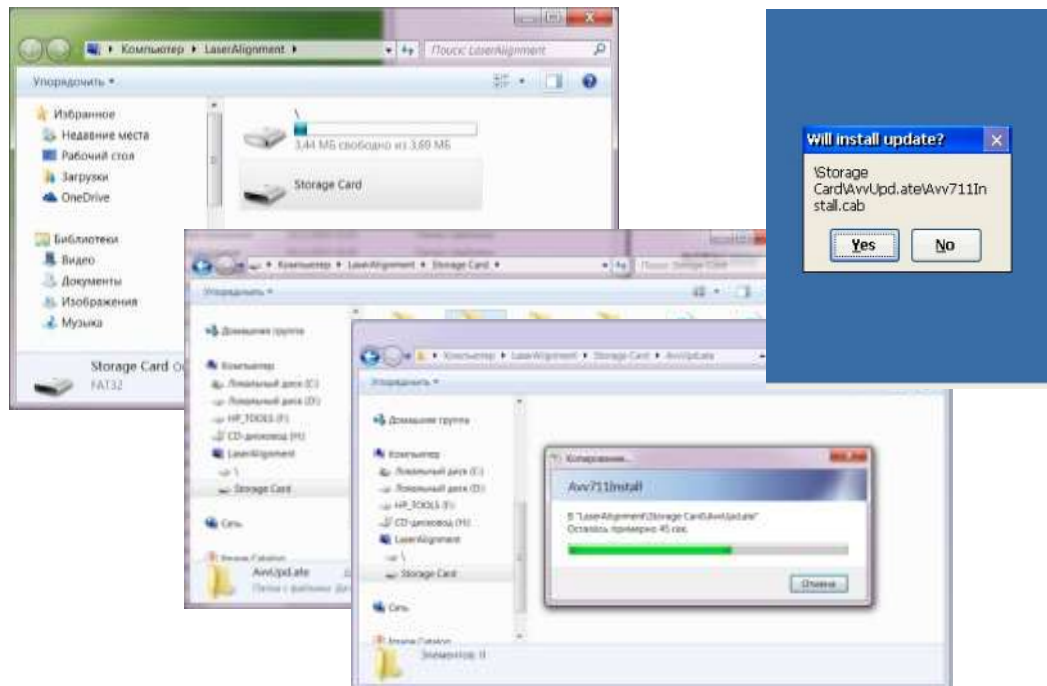

9. Wait until file copied.





10. Invoke firmware updaters by pressing     keys simultaneously.

11. Press  to confirm start of firmware upgrade.

12. Press  key then  to confirm  
replace of all existing files



13. Press  key to choose NO, then  
press 



14. Firmware upgrade will run. Once  
finished press  to turn device  
OFF



## STANDARD TOLERANCES OF SHAFT MISALIGNMENT

This chapter provides the standards alignment tolerance of misalignment for standard industrial machinery with flexible coupling that can be used under condition only if existing in-house standards or the machine or coupling OEM have not given any blinding values, and must not be exceeded.

Speed, rpm	Good		Acceptable	
	Offset	Angular (Gap)	Offset	Angular (Gap)
Up to 1000	0,08	0,07	0,12	0,10
Up to 2000	0,06	0,05	0,10	0,08
Up to 3000	0,04	0,04	0,07	0,07
Up to 4000	0,03	0,03	0,05	0,05
More than 4000	0,02	0,02	0,04	0,04

## DELIVERY SET

No	Description	Qty	Note
1.	Control Display Unit	1	
2.	Measuring Transducer Units S, M	2	
3.	Brackets Frame	2	
4.	Chains assembly	2	
5.	Supporting Rods	4	
6.	AC Charger, 100-240Volts	1	
7.	Tape Measure 2m	1	
8.	Carrying Case	1	
9.	Operating Instructions Manual (on internal SD card)	1	
10.	ConSpect Software (on internal SD card)	1	
11.	USB PC Communication Cable	1	

