



## **AVV-711**

LASER ALIGNMENT SYSTEM

USER'S MANUAL

**CONTENT**

General ..... 4

    Safety Precautions ..... 4

    Laser Safety Precautions ..... 4

    EC Declaration of conformity ..... 5

Technical Description ..... 6

    Designation ..... 6

    Misalignment Parameters ..... 7

    Specification and Features ..... 8

    System Package ..... 9

    System overview ..... 9

    Mounting Transducers ..... 10

    Laser Beam Adjustment ..... 11

Getting Started ..... 12

    Common control keys consideration ..... 12

    Auto save ..... 12

    Device setup ..... 12

    setup Menu Items ..... 13

Horizontal Machine Alignment ..... 15

    Short Explanation ..... 15

    Transducer's Positions Conventions ..... 15

    Parameters ..... 16

    Taking Measurements. Clock Mode. 3/4 Points ..... 18

    Taking Measurements. Multipoint Mode ..... 20

    Taking Readings. Auto Shooting mode ..... 21

Readings quality assessment ..... 21

Measurements edit Mode ..... 22

Result Screen ..... 23

Static-Movable machine swap ..... 23

Movable machine Adjustment ..... 24

Report file saving ..... 26

Soft Foot..... 27

Vertical Machine Alignment ..... 29

    Short Explanation..... 29

    Transducer's Positions Conventions ..... 29

    Parameters..... 30

    Taking Measurements. Clock Mode ..... 31

    Result Screen ..... 33

    Charging batteries..... 35

    Firmware Upgrade..... 36

    Firmware Upgrade Using Windows Mobile Device Center ..... 38

Remote Display ..... 40

Standard Tolerances of Shaft Misalignment ..... 41

Delivery Set ..... 42

## GENERAL

### SAFETY PRECAUTIONS

- ⚠ Be sure the machines to be measured, cannot be started unintentionally as this can cause injuries. For this purpose, before the mounting of equipment, either block the power switch in the "Off" position or remove the safety fuses. These precautionary rules must be followed until the measuring system is dismantled from the measured machine.

### LASER SAFETY PRECAUTIONS

The AVV-711 alignment system is the class II laser device at typical wavelength of 670nm, delivered output power of less than 1 mW and maximum radiant energy per pulse of 0.1 mJ. The Class II laser comply with requirement outlined by USA's FDA as well as international ANSI, BS 4803 and IEC 825 standard. Be sure to follow the following safety precautions to avoid personal injuries and damage to the system

- ⚠ **Do not look directly into the laser beam at any time!**
- ⚠ **Do not direct laser beam on to the people's eyes!**



#### **ATTENTION!**

Do not expose AVV-711 parts to heavy impacts, high humidity and extreme temperature.

Do not try open / dismantle measuring units and the display unit – this can damage the system, and your after-sales service warranty will come void.

#### **INJURY RESPONSIBILITY DISCLAIMER**

Neither the Alvib Sistemas, SL nor our authorized dealers are liable for the damages caused to machinery or equipment by use of the AVV-711 system. We carefully check text of this manual to eliminate errors, nonetheless there may be mistakes or inaccuracy involved. We will be grateful for your reporting to us about any error, and we will be able to correct them in the subsequent editions of the manual.

## EC DECLARATION OF CONFORMITY

Manufacturer: ALVIB Sistemas S.L., VAT: ES B10840346  
Escorpora 24,  
17252, Sant Antoni de Calonge, Spain

Product name: AVV-711

Description: Laser shaft alignment and geometrical measurement system

Model(s): AVV-711, AVV-711GEO

This declaration of conformity is issued under the sole responsibility of the manufacturer.

The object of the declaration described above is in conformity with the relevant Union harmonization legislation:

- 2014/30/EU – Electromagnetic Compatibility (EMC Directive)
- 2014/35/EU – Low Voltage Directive (LVD)
- 2011/65/EU – Restriction of Hazardous Substances (RoHS), including amendment (EU) 2015/863
- 2014/53/EU – Radio Equipment Directive (RED)

References to the relevant harmonized standards used:

EMC: EN 61326-1:2013, EN 55011:2016/A1:2017, EN 61000-6-2:2019,  
EN 61000-6-4:2019

Electrical Safety (LVD): EN 61010-1:2010/A1:2019

Laser Safety: EN 60825-1:2014 (Laser Class 2)

RoHS: EN IEC 63000:2018

Radio: EN 300 328, EN 301 489-1, EN 301 489-17

Additional information:

The product incorporates low-power visible laser sources classified as Class 2, safe under reasonably foreseeable conditions of operation.

Signed for and on behalf of:

Place of issue: Sant Antoni de Calonge, Spain]

Date: 1 July, 2022

Name: Oleg Ivanov

Position: Director

Company: ALVIB Sistemas S.L.

Signature:



## TECHNICAL DESCRIPTION

### DESIGNATION

**AVV-711** alignment system (further as System) is designed for measurement of shaft axis misalignment of coupled machines, and calculation of movable machine adjustment required to eliminate misalignment that exceeds permissible tolerances;

The machine alignment means adjustment of the relative position of two coupled machines (e.g. motor and pump) so that the center line of the axis will be concentric when the machines are running under normal working conditions.

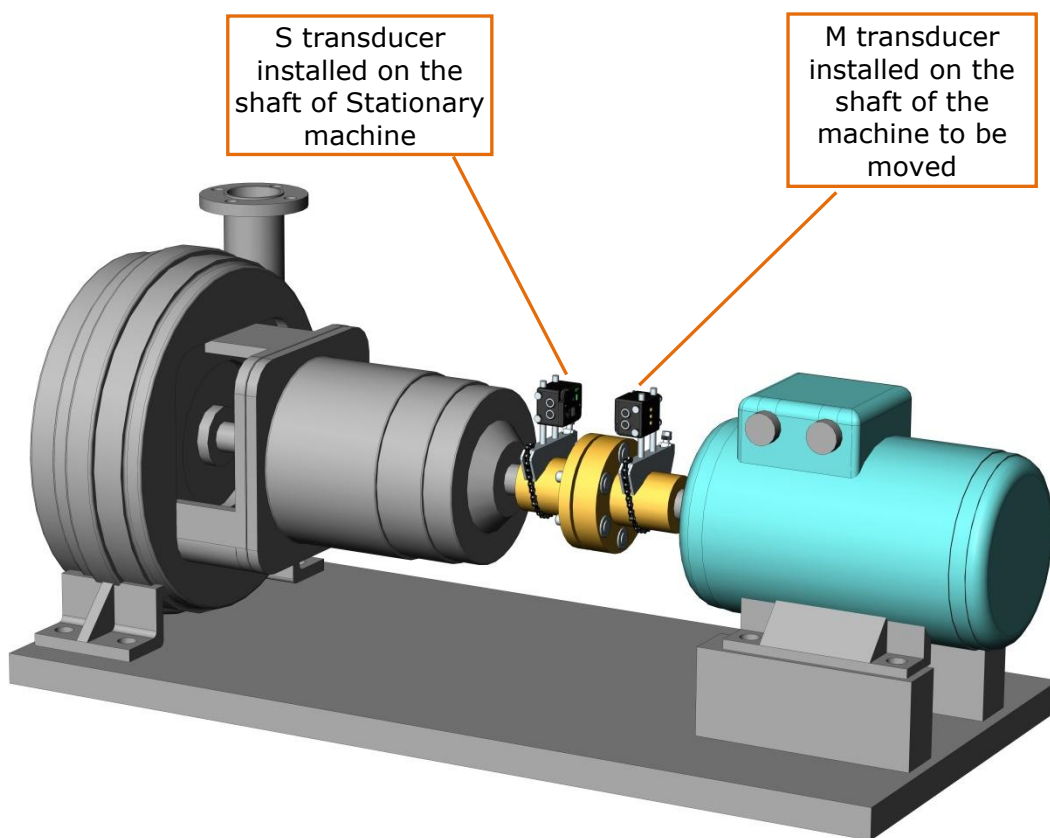

MISALIGNMENT PARAMETERS

Misalignment of any rotating machine is expressed in parallel (Offset) and angular (Gap) of the shafts. Most frequently in practice, both of them are present simultaneously. Different kinds of misalignment of axes are shown in Fig. 2.



|   |  |
|---|--|
|  | Parallel misalignment of axes – Offset (displacement)      |
|  | Angular misalignment of axes – Gap                         |
|  | Parallel and angular misalignment of axes – (Offset + Gap) |

Fig 2

The parallel (Offset) and angular (Gap) misalignment of axes is determined in two mutually perpendicular planes. For the purpose of elimination of the parallel and angular misalignment of axes, in each of the planes a correction of position of the movable machine (M) will be done.

For the horizontal mounted machine – the movable machine (M) position is adjusted in the horizontal and vertical planes.

For the vertical mounted machine, operator determines arrangement of the correction planes, basing on considerations of the convenience and technological effectiveness of moving of the movable (M) machine.

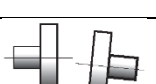
*Stationary machine (S) - in the process of eliminating of the axes misalignment the position of this machine stay static, i.e. it does not move.*

*Movable machine (M) – the machine, which position is adjusted for eliminating of the parallel and angular misalignment of axes.*

The measurement system calculates the values of the angular and parallel misalignment of axes in the plane of the coupling (in two mutually perpendicular planes), and the adjustment values for the machine feet on the movable (M) machine, that is necessary for elimination of this misalignment of axes. Fig. 3 shows misalignment of axes and the values for its correction just for vertical plane.

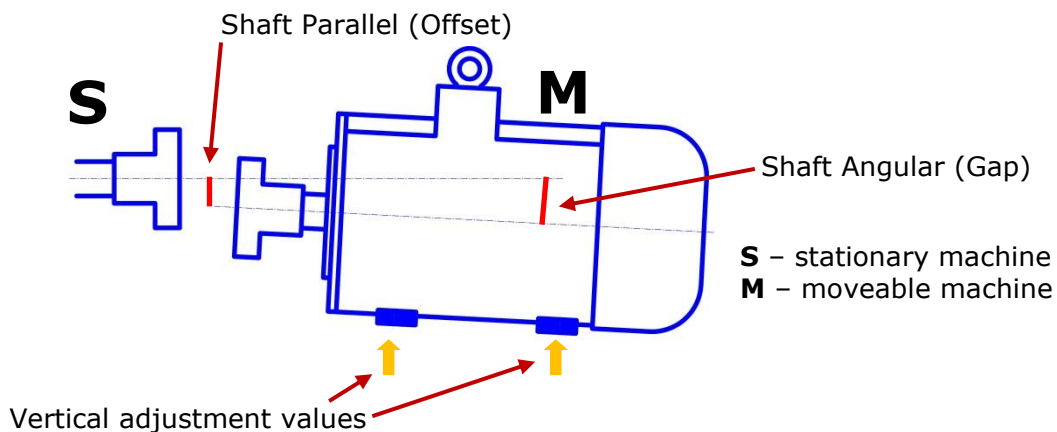

## SPECIFICATION AND FEATURES

- Separation distance between measuring transducer units S and M:
  - AVV-TSM100 up to 10 m
  - AVV-TSM400 up to 20 m
- Display control operating temperature range, -10..+55 degree C
- Measurement accuracy, 1%+0.01
- Laser type: Visible red 635-670 nm, <1 mW
- Detector type: Positional-sensitive photodiodes:
  - AVV-TSM100 10x10 mm
  - AVV-TSM400 20x20 mm
- Display resolution, 0.01 or 0.001 mm, (1 or 0.1 mil )
- Measuring resolution, 0.001mm
- Electronic inclinometer resolution, 0.1 degree
- Power supply: Rechargeable Li-Ion battery
- Gross weight, incl. carry case, 6.5 kg
- Built-in application programs and options:
  - o horizontal shaft alignment at any shaft position, from 60°, up to 360°, up to 36 readings can be measured; auto sweep mode can be used;
  - o vertical (flange machine) shaft alignment;
  - o editable misalignment tolerances;
  - o setup options;
  - o soft foot;
  - o thermal growth;
  - o shimming simulator to calculate for expected residual misalignment;

SYSTEM PACKAGE

The System includes (Fig. 1):

- 1- AVV-711 display unit
- 2- two measuring transducer units – S, M
- 3- universal chain brackets for mounting of measuring units S, M
- 4- 3m tape measure
- 5- 120...240 USB wall charger
- 6- USB PC communication cable
- 7- Operating instructions manual and ConSpect freeware on the internal drive of display unit
- 8- Carry case



SYSTEM OVERVIEW

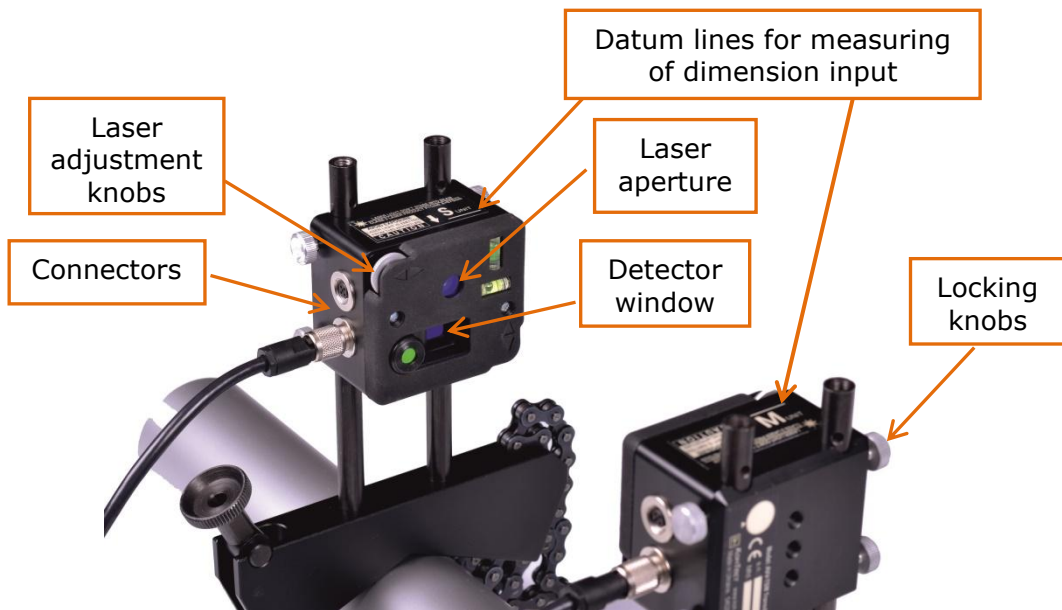



## MOUNTING TRANSDUCERS

- Firmly tighten rods 1 into the shaft brackets 2.
- Put thumb nut 3 into the bracket 2, then hook the chain 5 on the stud 4.
- Firmly tighten the thumb nut 3. Shaft brackets with rods must be mounted at the same angular position.
- Mount transducers on the rods. Always try to mount transducers at minimal possible radial height. Make sure that transducers are not touching brackets or machine parts.

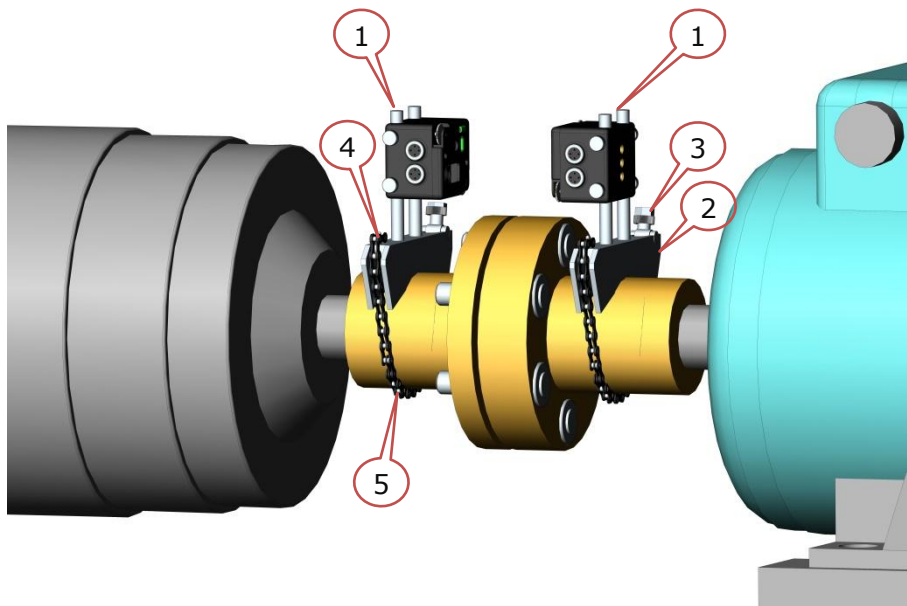

## LASER BEAM ADJUSTMENT

- Mount transducers at the same height relative to the axis of the shafts
- Close transducers windows and use green circle as the target
- Adjust laser beams to the centers of targets by means of adjustment knobs
- Open transducers windows

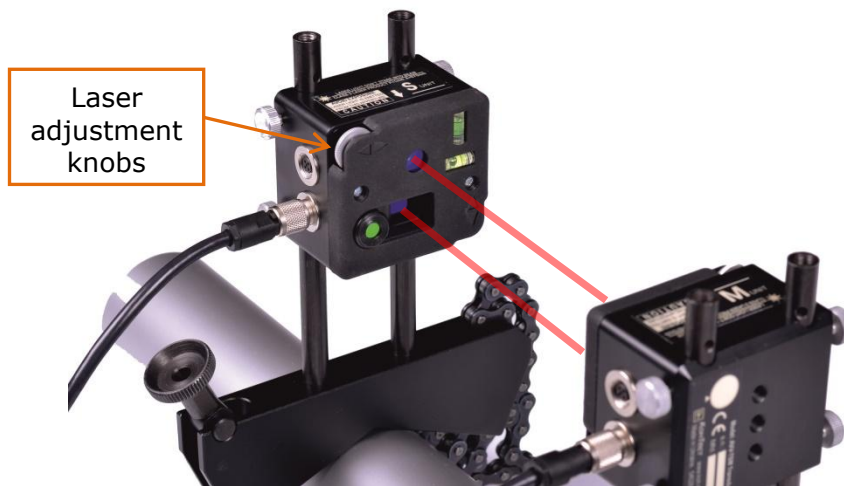



## GETTING STARTED

### COMMON CONTROL KEYS CONSIDERATION

To turn ON/OFF display unit and transducers – press and hold the power button  for ~2 sec.

In case the system hangs and device did not respond to any keys - press and hold the power button  for ~10 sec, the system will be reset.

To close any currently active window, without saving, except main menu of the device, press  button (it serves as escape key).

The  button in most cases causes applying (saving) changes (invoke selection) and exit (from edit box; or from current window, except such windows as collect data, aligning, soft foot and so on where it is not applicable).

To invoke menu item – move cursor to this item and press  key, or just press the shortcut key regardless of the cursor position. In most cases the shortcut key is depicted left to the menu item.

### AUTO SAVE

All procedures are designed with auto save. For temporarily shut down your current work press  until program exits to main menu of the device. Data saved now and device can be turned off.

### DEVICE SETUP

To invoke Setup menu – move cursor to

**Setup** and press  button.

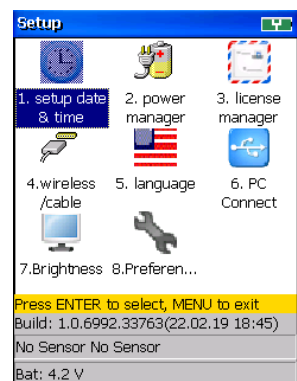
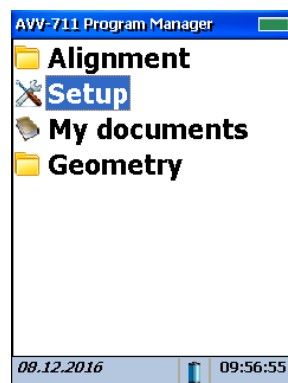

SETUP MENU ITEMS



1. setup date & time – to setup date and time

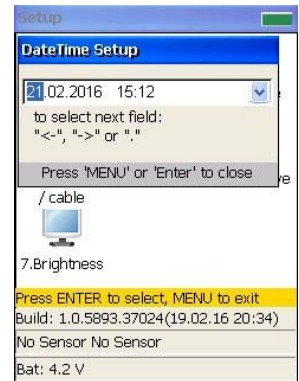

2. power manager – to set device auto off delay in seconds. Auto off timer is disabled when set to 0.

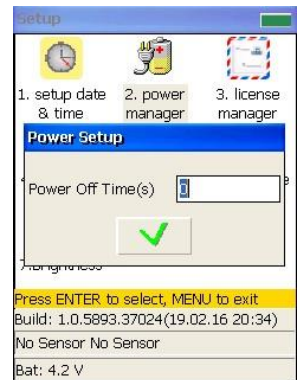

3. license manager – to install license file which enables measurement functions. Press 9, browse to the license file, press Enter to open and install licenses.

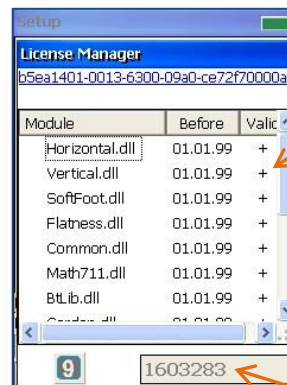

+ Function enabled, valid till 01.01.2099

Serial number



4. wireless /cable – to switch between wireless/cable transducers connection. For wireless connection – press 1 or 2 to enter number of transducers to be connected

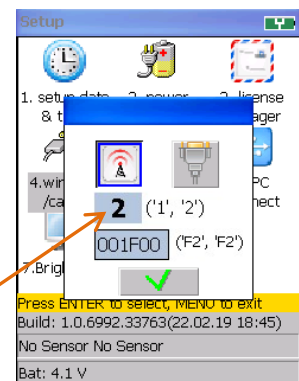

Number of transducers to be connected



5. language

- to choose user interface language

Use keys to choose language, then press



6. USB drive

- to switch AVV-711 into USB mass storage device mode. By default device

can be connected to the PC via Microsoft Windows Mobile Device Center. USB mass storage device mode can be used as alternative.



7. Brightness

- to adjust the display backlight brightness

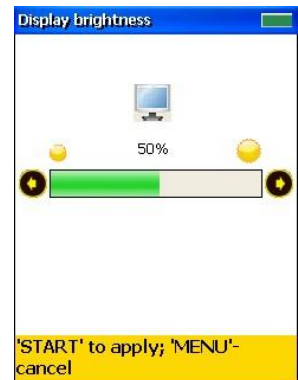

8. Preferen...

- to choose default alignment mode 1-D or 2-D biaxial mode. In biaxial mode both horizontal and vertical machine aligning could be made at a static transducers position (e.g. 3 h).

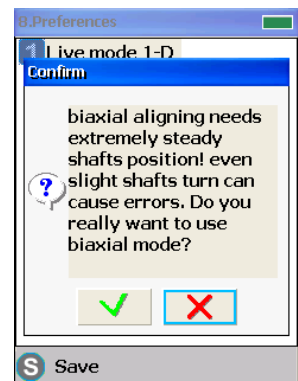
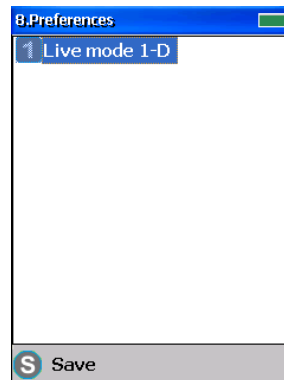

## HORIZONTAL MACHINE ALIGNMENT

### SHORT EXPLANATION

- Mount transducers on shafts
- Run Horizontal program
- Enter dimensions
- Set parameters. E.g. Measurement mode – clock type (9-12-3 o'clock positions)
- Turn shafts with transducers at first position 9 o'clock (90°). Press Start to take readings
- Turn shafts with transducers at second position 12 o'clock (180°). Press Start to take readings
- Turn shafts with transducers at last position 3 o'clock (270°). Press Start to take readings
- After that the device will calculate misalignment and displays required corrections for Movable machine

### TRANSDUCER'S POSITIONS CONVENTIONS

While taking measurements, it is necessary to follow conventions for transducers positions on the shafts with the S and M measuring transducers with regard to the relative position of the S and M machines as depicted on the figure.

Angular positions in degrees adopted in the device are as follows:

6 o'clock - 0°

9 o'clock - 90°

12 o'clock - 180°

3 o'clock - 270°

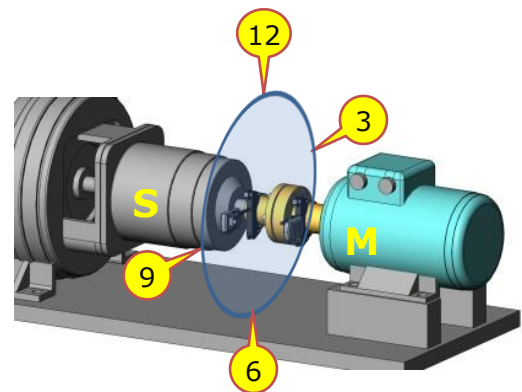

PARAMETERS

In Main Menu run **Horizontal** program.

Choose **New Task** to start from scratch or **Continue...** - to resume interrupted work.

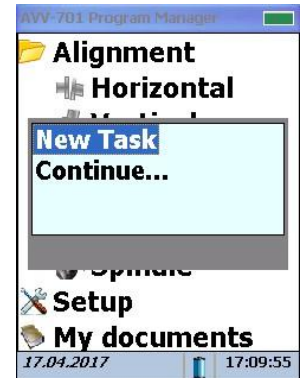

Machine dimensions / measurement setup screen

Press  key to start editing the dimensions' values

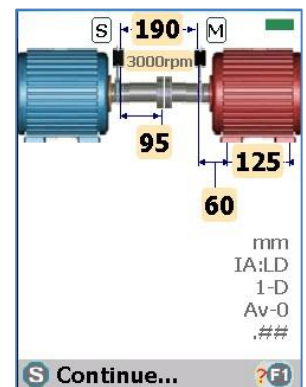

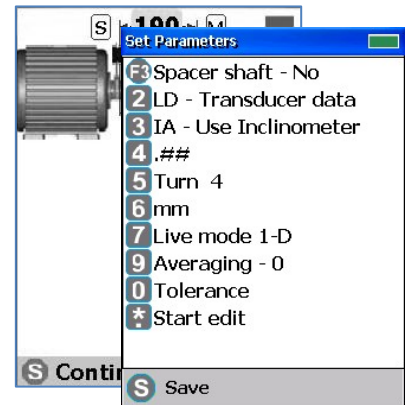

Press  key for parameters/key legend:



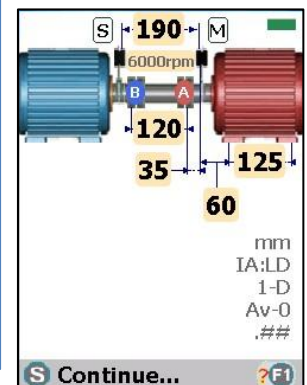
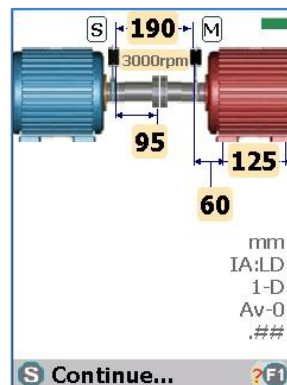

Press  - to toggle Spacer shaft **Yes/No**



Press  - to toggle data input – **LD** transducer's data / **MD** – manual data

Press  - to toggle angle input – **IA** use inclinometer / **MA** manual angle. Manual angle input used for vertical machines, when electronic inclinometer cannot be used.

Press  - to toggle displayed precision – 2 or 3 digit.

Press  - to toggle measurement mode:  
**Turn 3** point (e.g. clock mode 9-12-3 o'clock),  
**Turn 4** point – readings to be taken at four predefined shaft positions separated by 45° or 90°. After that the device itself will proceed to the result screen.

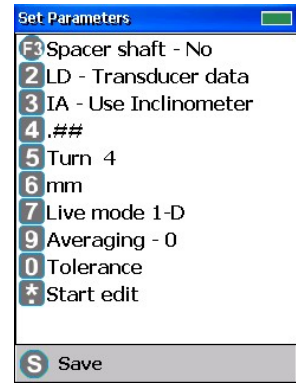
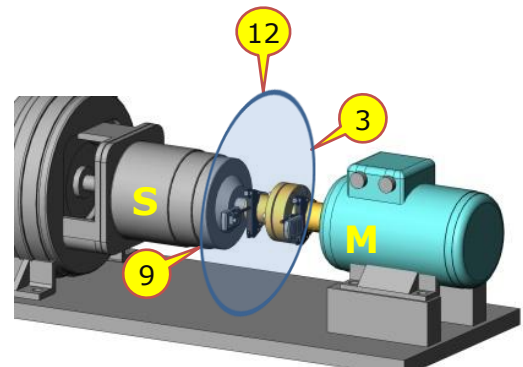



**Multipoint** mode – measurements may be taken

at any minimum 3 up to 36 positions. After taking enough readings one should press  to proceed to the result screen.

Press  to toggle metric/imperial units mm/in



Press  to toggle 1-D / 2-D Biaxial alignment mode

Press  to setup Averaging. When set to 0 Averaging is turned off.

Press  to enter tolerance setup menu.

Press  to use predefined RPM/tolerance table

Press  to enter user defined tolerance values

Press  to save changes,  to discard changes.

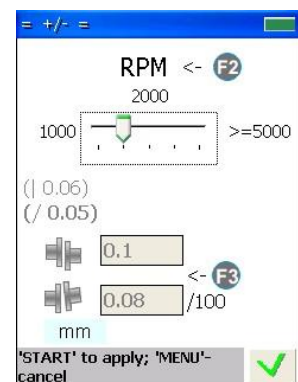

TAKING MEASUREMENTS. CLOCK MODE. 3/4 POINTS

Press  to edit dimensions.

Set parameters and enter dimensions then press  key to proceed.

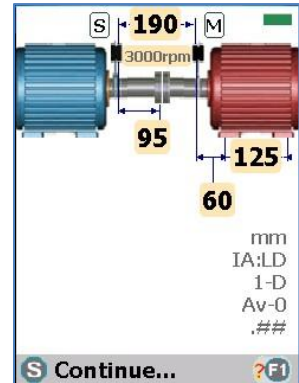

Turn shafts to first position – 9 o'clock (90°)

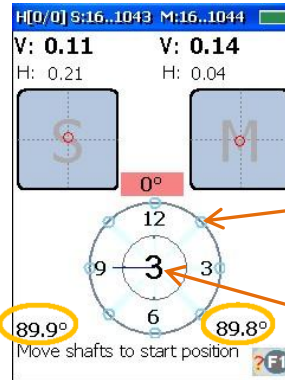
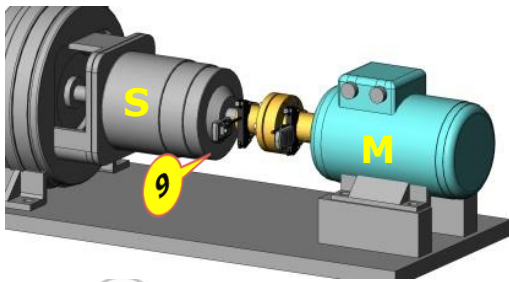

Predefined positions transducers should be turned to take readings

- 3 – clock mode
- 4 – 4 pnt clock mode
- \* – multipoint

Press  to take first reading.

Yellow clock face means that point is already collected and shafts should be turned to the next position.

First reading

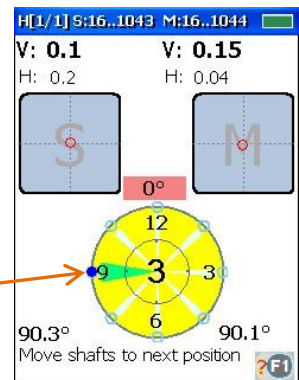

Turn shafts to second position – 12 o'clock (180°)

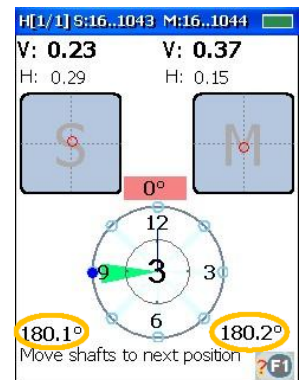
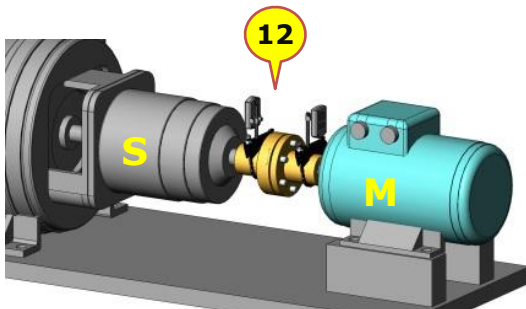

Press  to take second reading.

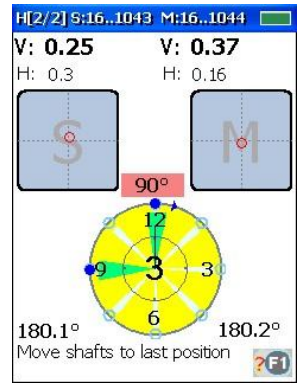

Turn shafts to third position – 3 o'clock (270°)

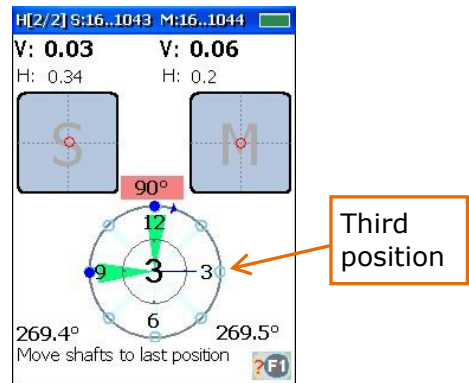
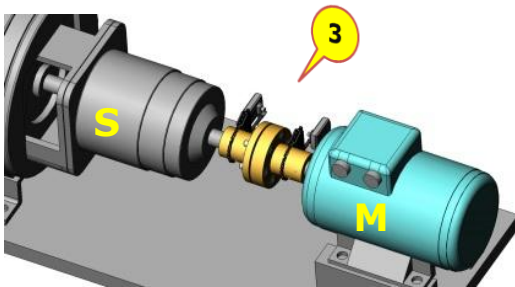

Press  to take third reading. When three readings are taken, the device will proceed to the result screen. For 4 points mode, one more position should be measured. This mode can be used when advanced alignment precision is required.

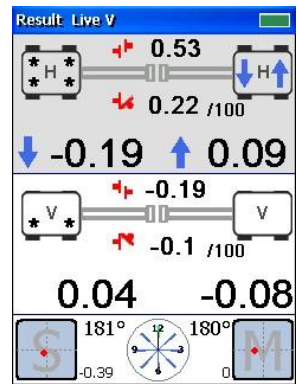
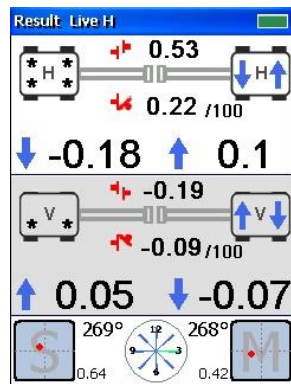

TAKING MEASUREMENTS. MULTIPOINT MODE

In multipoint mode readings can be collected at any shafts position minimum 3 up to 36 positions.

AVV-711 is able to calculate misalignment after collecting at least 3 points within as little as 70 degree range. **However always try to cover as wide shaft turn angle as possible.**

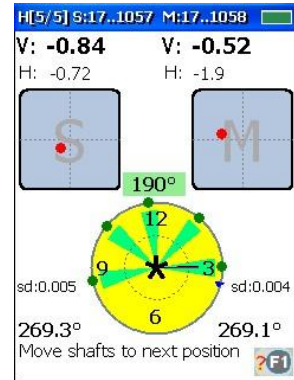

Press  to take reading, and then turn shafts to next position.

Yellow clock face means that point is already collected and shafts should be turned to next position.

When enough readings are collected – press  to proceed to the result screen.

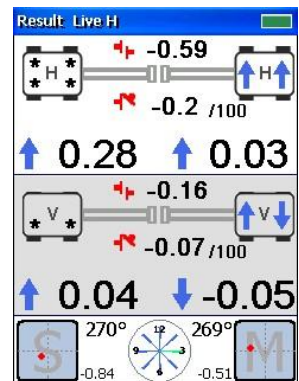

TAKING READINGS. AUTO SHOOTING MODE

Turn shafts to first position, then press **F4** key to activate auto shooting mode.

Auto shooting mode is active

When auto shooting mode is active – device waits for stable shaft position then automatically records data and prompts to move shafts to the next position.

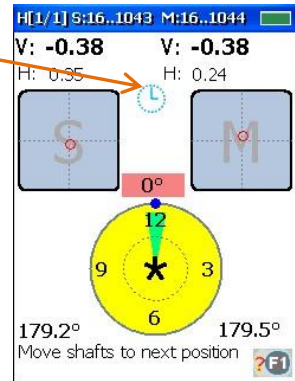

Auto shooting mode can be activated in both Clock mode and Multipoint mode.

When device is in Multipoint mode and enough readings are collected – press **F5** to proceed to the result screen.

When device is in Clock mode and 3 (or 4) readings are taken device will automatically proceed to the result screen.

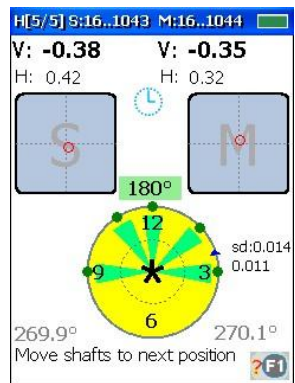

READINGS QUALITY ASSESSMENT

When taking readings, device performs assessment of data quality based on standard deviation (SD value). Quality is indicated by color of dots at measurement positions:

Blue – assessment is impossible (too few points collected)

Green – good quality

Yellow – acceptable quality

Red – poor quality, must be re-measured or deleted.

The factors which may affect readings – high vibration, partial clipping of the laser beam, mechanical looseness, accidental alteration of transducers position (e.g. by touching it).

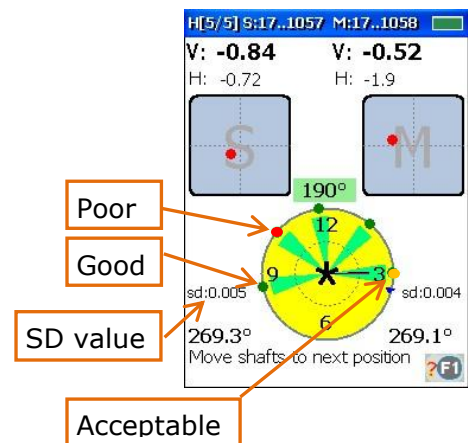

Readings quality assessment is useful option which helps to detect such conditions.





MEASUREMENTS EDIT MODE

It is possible to edit collected data when poor quality data is detected.

Press  key to activate edit mode

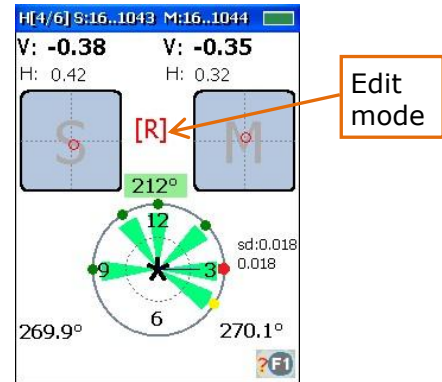
Use   keys to scroll over collected readings



Use  to delete readings

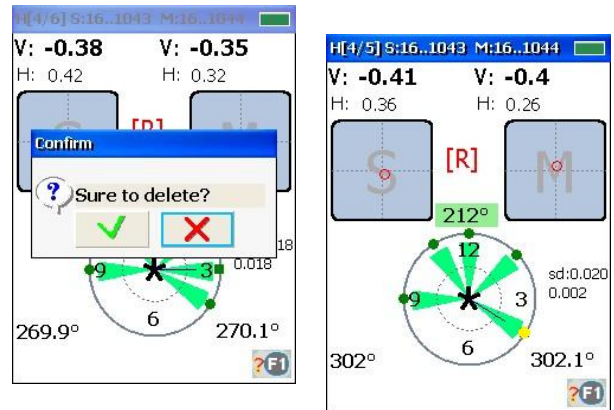

Use  key to quit edit mode (press until cursor points to the last measurement, then quit)

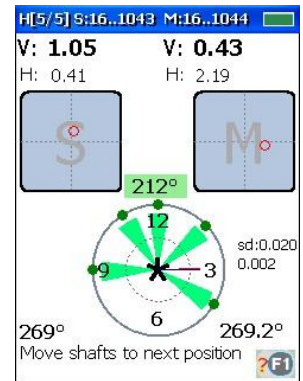

RESULT SCREEN

On the result screen device displays parallel and angular misalignment at the coupling and values of the required corrections in horizontal and vertical directions for movable machine. Blue arrows clearly displays directions in which movable machine must be moved to eliminate misalignment.

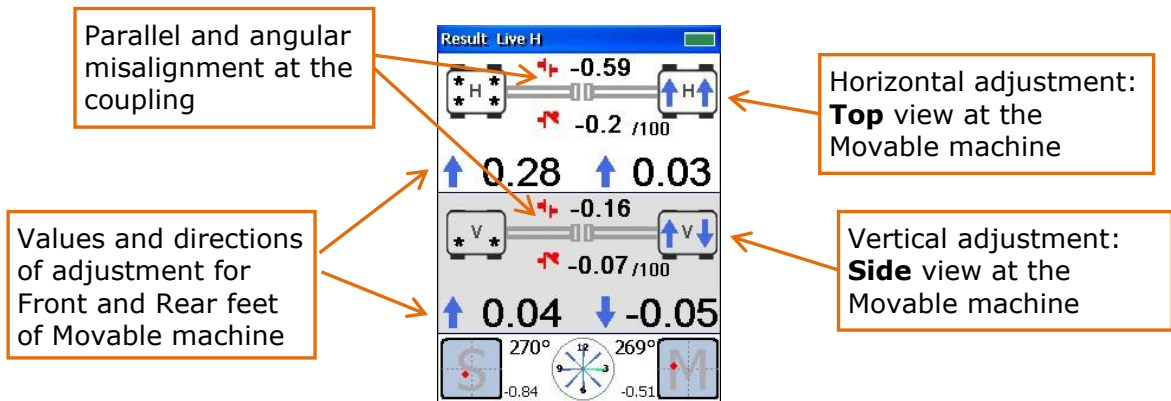

STATIC-MOVABLE MACHINE SWAP

Fixed feet of Static machine are indicated by asterisks.

It is possible to swap Static and Movable machine when needed. To do so:

Fixed feet

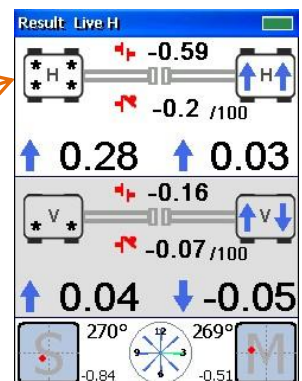



Press 

Device will prompt to enter missed dimensions

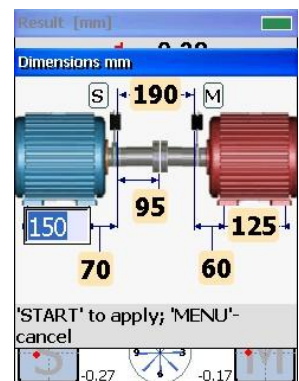
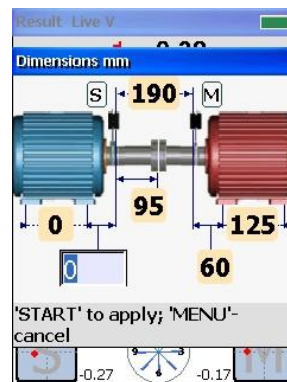
Enter dimensions then press  to confirm and device will proceed to Feet lock menu



Use   to choose machine

Press  to fix feet (make machine Static)

Press  to confirm

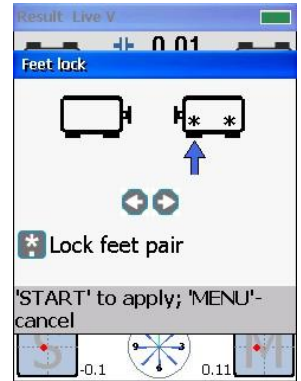

Device will recalculate correction values for current Movable machine

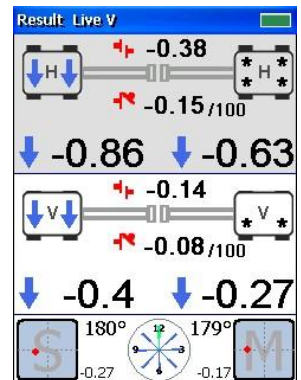

## MOVABLE MACHINE ADJUSTMENT

To make adjustment in **vertical** direction transducers must be turned to 6 or 12 o'clock (0° or 180°) position.

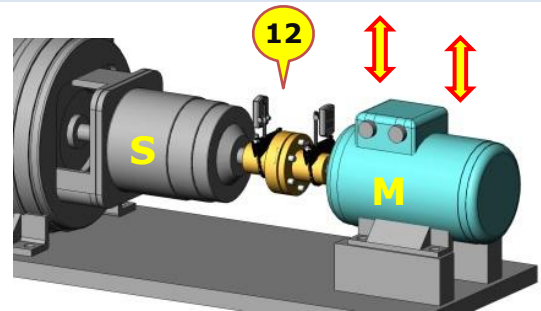

To make adjustment in **horizontal** direction transducers must be turned to 9 or 3 o'clock (90° or 270°) position.

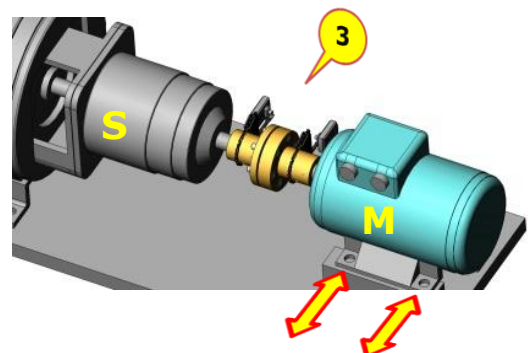

Device may reduce number of available transducers positions for machine adjustment. Permissible transducer positions are indicated at the clock face. Only permissible transducer positions can be used for machine adjustment.

Transducers now at 3 o'clock (270°) live data for H direction

Data for V direction are frozen (display shaded) until transducers are not turned to 12 or 6 o'clock

Permissible transducers positions

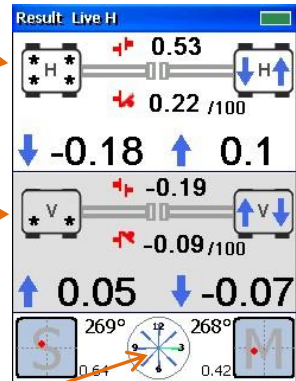

It is possible to perform both Vertical and Horizontal machine alignment at static shafts position (at any of four x45° positions – 1:30, 4:30, 7:30, 10:30).

Transducers now at 1:30 o'clock (225°) live data for H direction

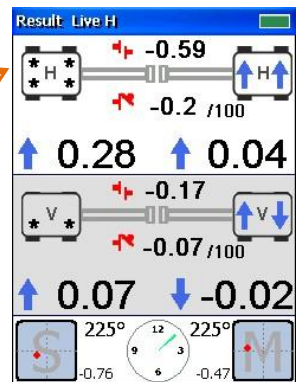

Only one direction at a time – Horizontal or Vertical must be adjusted.

Use  key to choose which of planes to be adjusted.

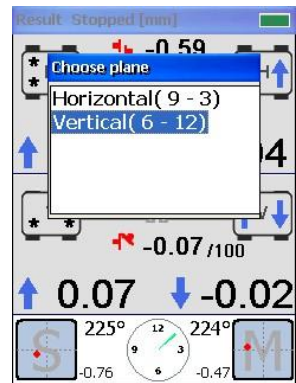

Transducers now at 1:30 o'clock (225°) live data for V direction

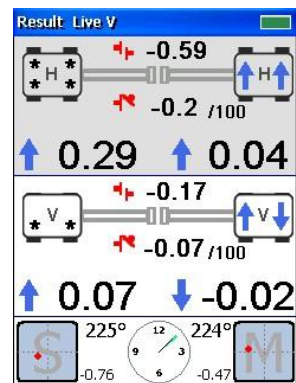



REPORT FILE SAVING

Report file can be saved at any stage of alignment

To save report file – press  key in the result screen

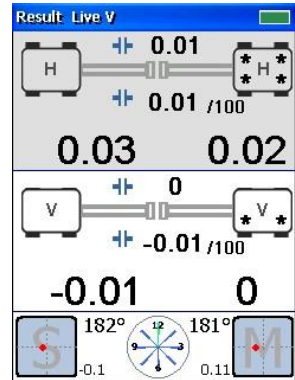
Reports can be saved to internal SD card or to thumb drive connected to USB host socket of AVV-711



Use  key to choose drive

Use       keys to browse folders

Use  to open folder

Use  to move one level up

Use  to create new folder

Use  turn on/off PDF reports generation

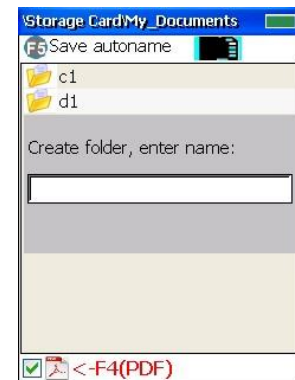
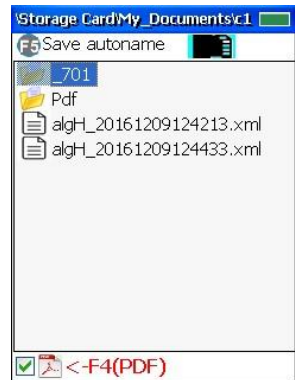

Press  or  key to save report with default name

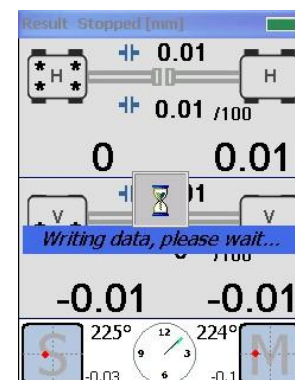

Press  to edit file name



## SOFT FOOT

Soft foot condition makes impossible proper machine alignment. So it should be eliminated prior to conduct alignment work. Soft Foot program intended for this purpose.

Run **Soft Foot** program.



Press  to edit distances

Enter distances

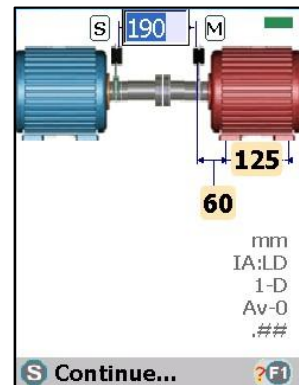
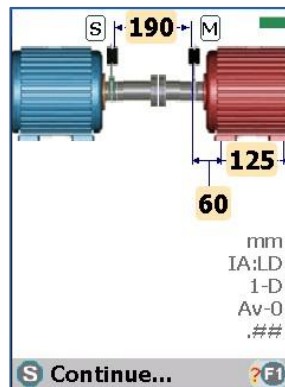

Make sure that all foos are tightened.

Turn shafts with transducers at 12 o'clock position.

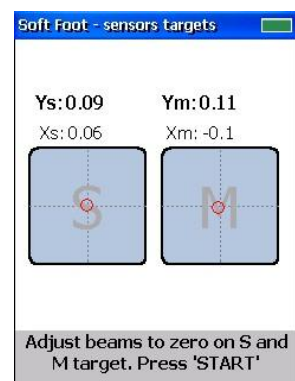
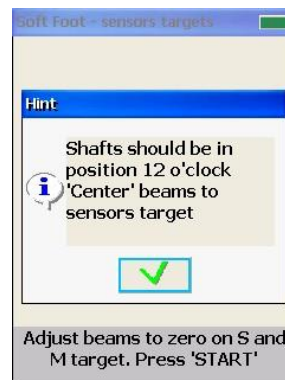

Press  key to proceed.

- Loosen first bolt fully
- Wait about 5 sec
- Press  key
- Tighten bolt firmly

- Press  key
- Repeat this procedure for all feet
- Press  to save file

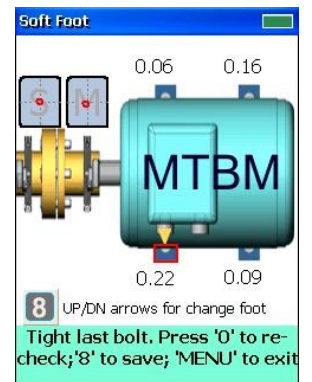
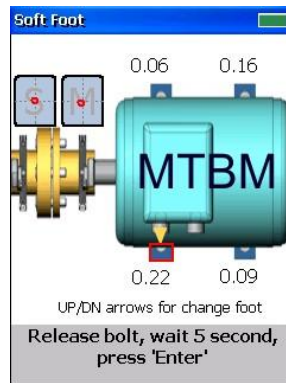
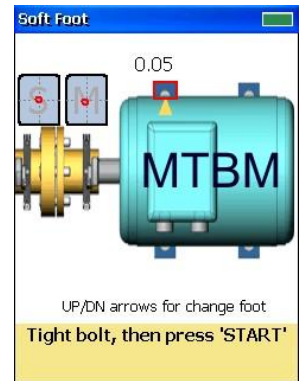
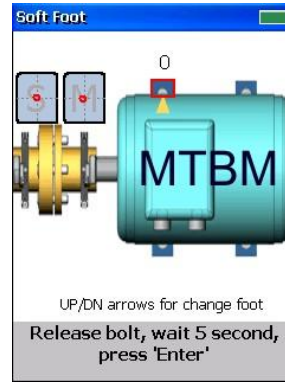

Bolt selection sequence can be changed by manually selecting the bolt by arrow keys.

## VERTICAL MACHINE ALIGNMENT

### SHORT EXPLANATION

- Mount transducers on shafts
- Run Vertical program
- Mark on the machine three positions spaced by 90° (9-12-3 o'clock positions)
- Enter dimensions
- Set parameters. E.g. Tolerances.
- Turn shafts with transducers at first position 9 o'clock (90°). Press Start to take readings
- Turn shafts with transducers at second position 12 o'clock (180°). Press Start to take readings
- Turn shafts with transducers at last position 3 o'clock (270°). Press Start to take readings

After that device will calculate misalignment and displays required corrections for Movable machine

### TRANSDUCER'S POSITIONS CONVENTIONS

While taking measurements, it is necessary to follow conventions for transducers positions on the shafts with the S and M measuring transducers with regard to the relative position of the S and M machines as depicted on the figure.

Angular positions in degrees adopted in the device are as follows:

6 o'clock - 0°

9 o'clock - 90°

12 o'clock - 180°

3 o'clock - 270°

The electronic inclinometers cannot be used on the vertical machines, so "Manual angle" is set by default. One should mark measurement positions on the machine prior to start measuring.

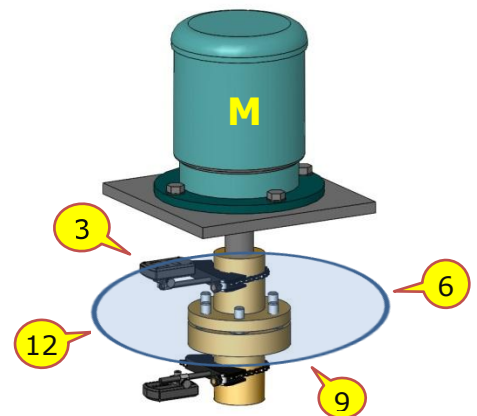

PARAMETERS

Run **Vertical** program.

Choose **New Task**.

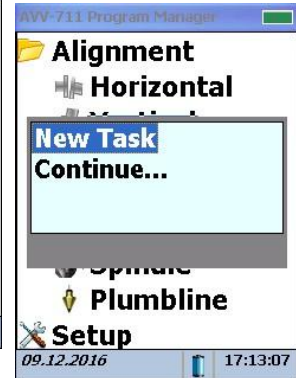

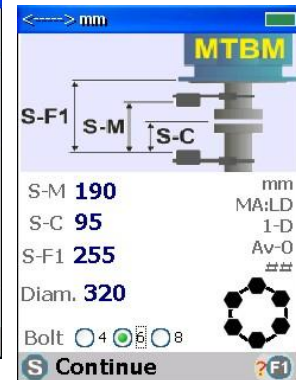
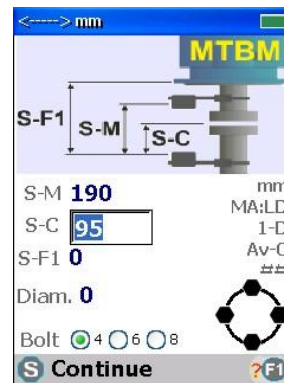

Machine dimensions / measurement setup screen

Press  key to start editing dimensions values





Press  key for parameters/key legend:

Press  - to toggle data input – LD transducer's data / MD – manual data

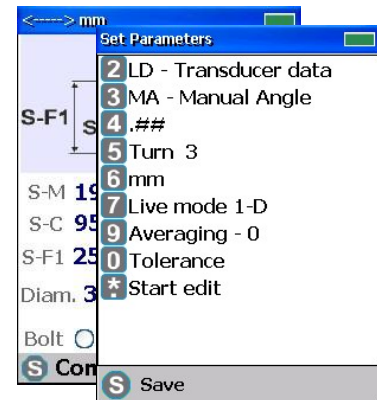
Press  - to toggle angle input – IA use inclinometer / MA manual angle. Manual angle input used for vertical machines, when electronic inclinometer cannot be used.



Press  - to toggle displayed precision – 2 or 3 digits.

Press  - to toggle measurement mode: Clock mode **3 Point/4 Point** – readings to be taken at three or four predefined shaft positions – 3, 6, 9, 12 o'clock. After that the device will proceed to the result screen.

**Multipoint** mode – measurements may be taken at any minimum 3 up to 36 positions.

After taking enough readings one should press  to proceed to the result screen. For

Vertical machines inclinometer data is unavailable, so angle value for each point should be entered manually, taking into account mentioned above positions conventions.

Press  key to enter angle of transducers position.

Or any of 45° positions can be used

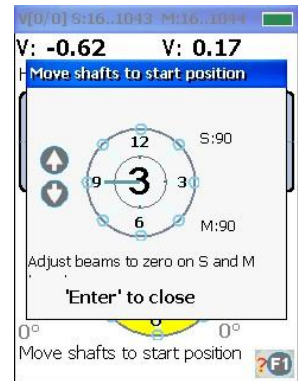

Press  to enter tolerance setup menu.

Press  to use predefined RPM/tolerance table

Press  to enter user defined tolerance values

Press  to save changes,  to discard changes.

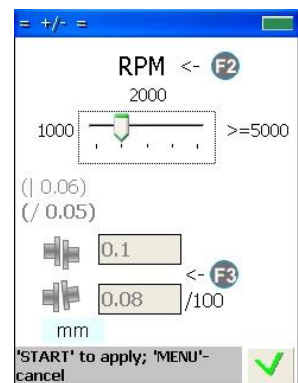

## TAKING MEASUREMENTS. CLOCK MODE

Press  to edit dimensions.

Set parameters and enter dimensions then press  key to proceed.

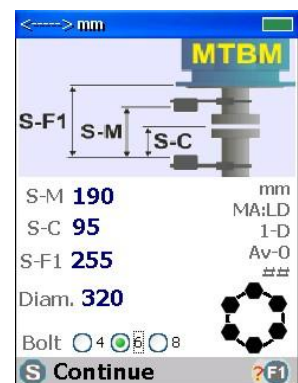

Turn shafts to first position

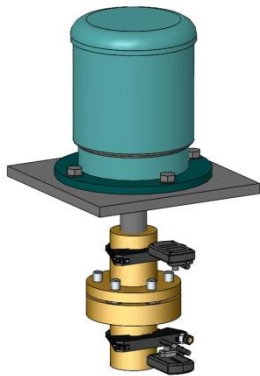

Use   keys to indicate actual transducers position

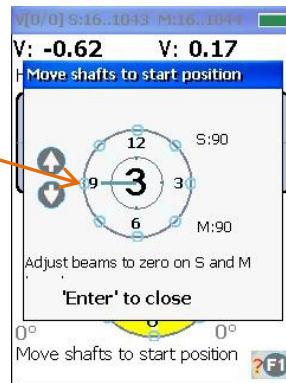

First reading

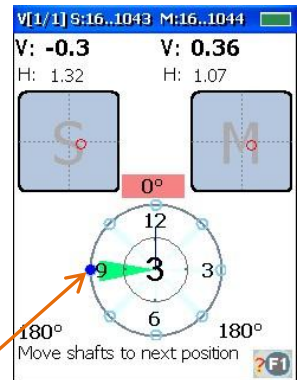

Make sure that actual transducers position is

indicated then press  to take the first reading.

Turn shafts to next position

Press  to take second reading.

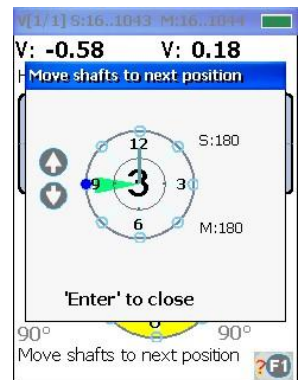

.. and finally turn shafts to the last position

Press  to take reading.

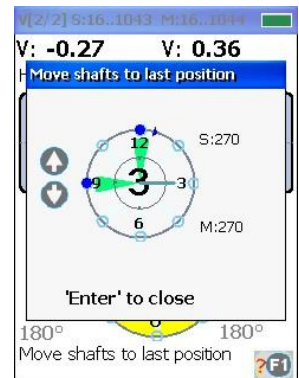

When all reading are taken device will proceed to the result screen.

RESULT SCREEN

At this moment transducers are at 1:30 o'clock (225°) position, device displays live updated values for 9-3 direction.

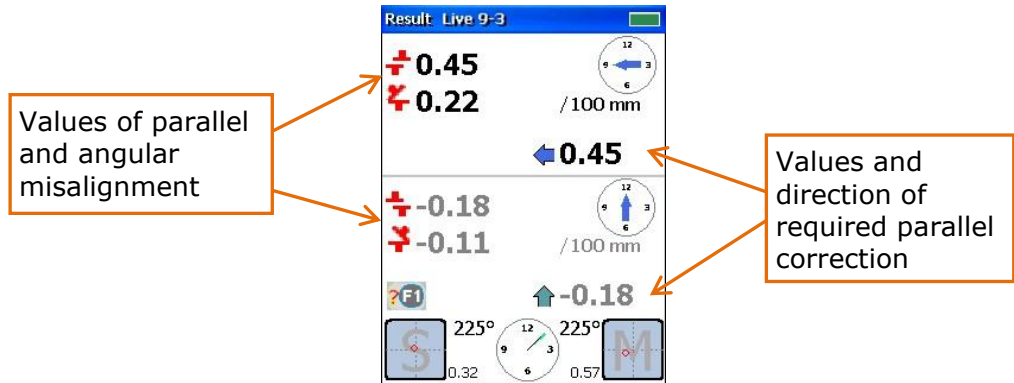

Blue arrows displays directions, in which movable machine must be moved to eliminate parallel misalignment.

Press  key to toggle between parallel/shimming values screens.

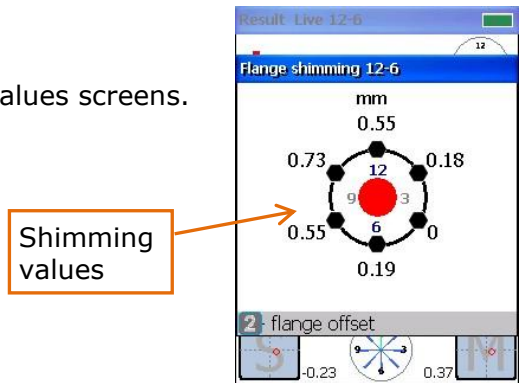

Since transducers are at x45°, 1:30 o'clock (225°) position there is no need to turn shafts to make adjustment in 6-12 plane, just press  key to choose which of planes to be adjusted.

When one of x90°, 3, 6, 9, 12 o'clock transducers position is used for machine alignment:

To make adjustment in **6-12** direction transducers must be turned to 6 or 12 o'clock (0° or 180°) position.

To make adjustment in **9-3** direction transducers must be turned to 9 or 3 o'clock (90° or 270°) position.

Press  key to choose which of planes to be adjusted.

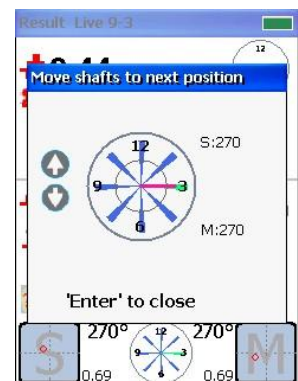

Color of coupling signs indicates value of misalignment. Green color indicates when residual misalignment is within tolerance. Black color is for perfect result. Always stop machine correction when residual misalignment is within tolerance. Do not try to reach zero.

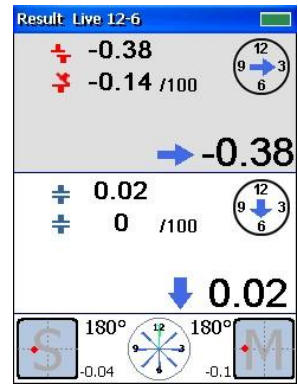

## CHARGING BATTERIES

The battery can be charged by means of USB type AC charger or via PC/laptop USB port.

Immediately after connecting charger to the display unit there is a few seconds span to change charge current - press and hold ON button for ~2sec until LED changes flash rate.



Low flash rate - normal charge, high rate - fast charge. Keep in mind that in most cases PC/laptop USB port can only provide normal charge.

The LED will turn off when battery is fully charged.

FIRMWARE UPGRADE

Make sure that device battery is fully charged!

1. Insert USB thumb drive into PC/Laptop port. In the root directory of USB thumb drive – create the folder **AvvUpd.ate**

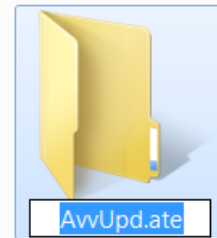

2. Copy firmware file **Avv711Intall.cab** to this folder

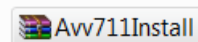

3. Remove USB thumb drive from PC/Laptop port and insert it to the AVV-711 USB host port. Press and hold  key for ~2 sec to turn AVV-711 on.

4. Invoke firmware updater by pressing





5. Press  to confirm search for USB



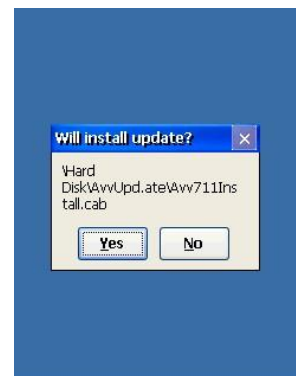

6. Press  to confirm start of firmware upgrade.

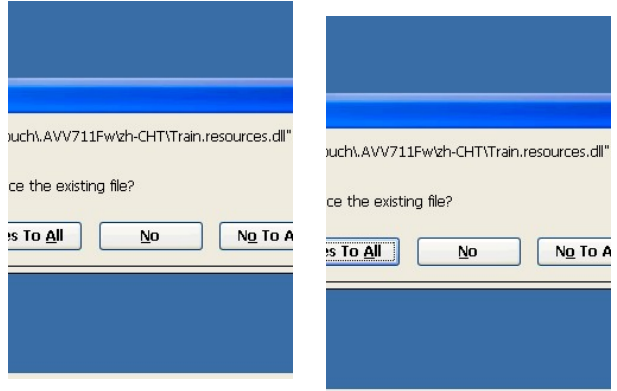

7. Press  key then  to confirm replace of all existing files



8. Press  key to choose NO, then press 

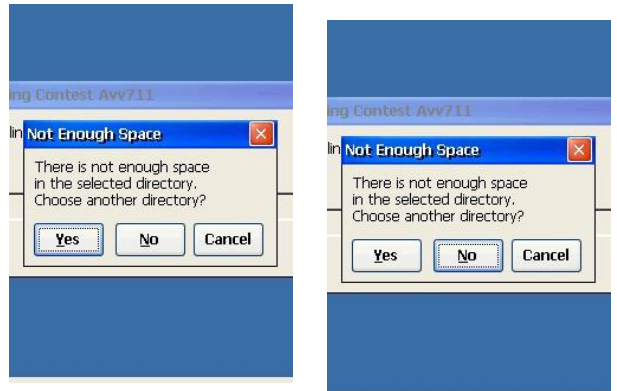

9. Firmware upgrade will run. Once finished press  to turn device OFF

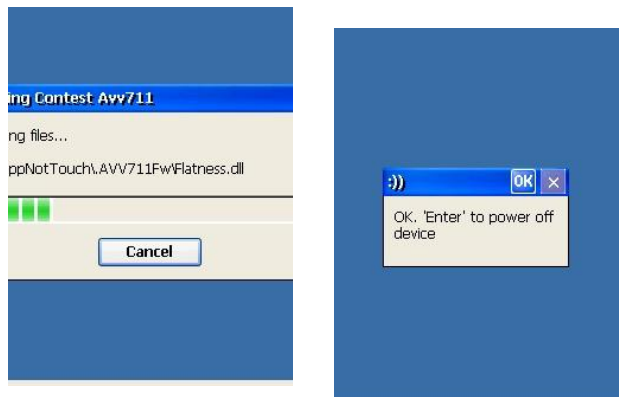



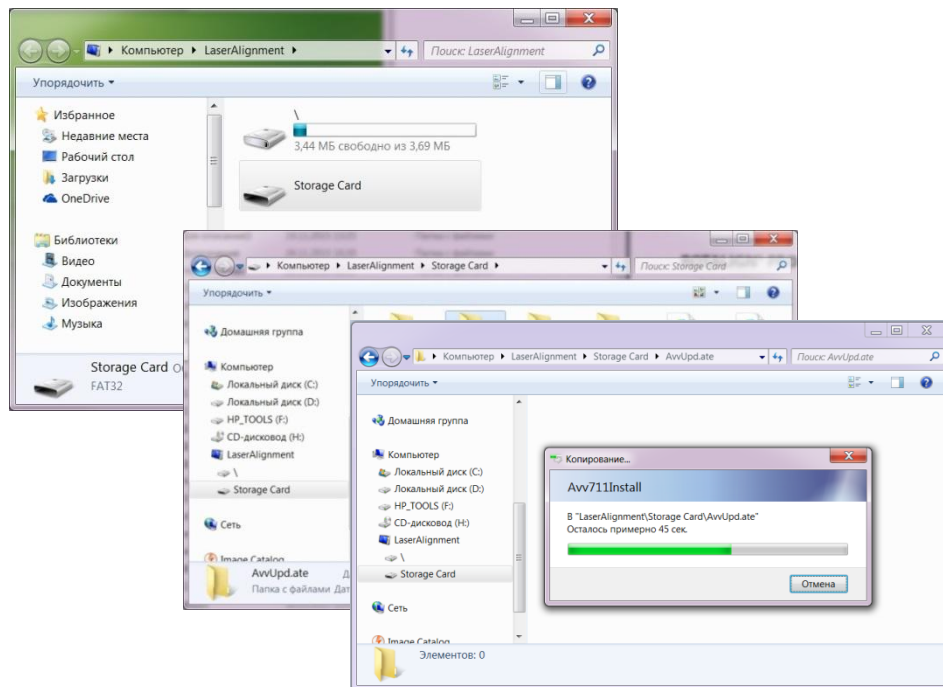

FIRMWARE UPGRADE USING WINDOWS MOBILE DEVICE CENTER

Make sure that device battery is fully charged!

1. Connect AVV-711 to PC via USB cable. Press  key for ~2 sec to turn AVV-711 on. Windows Mobile Device center will launch. Connect to AVV-711 and browse to the folder "Storage Card/LaserAlignment/AvvUpd.ate/" and paste there the firmware file **Avv711Install.cab**





2. Wait until file copied.

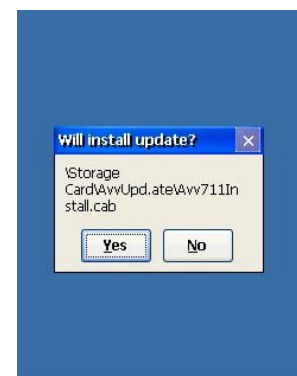

3. Invoke firmware updater by pressing     keys simultaneously.

4. Press  to confirm start of firmware upgrade.

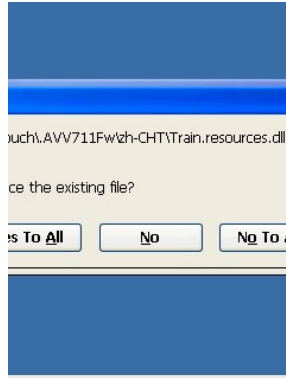

5. Press  key then  to confirm replace of all existing files



6. Press  key to choose NO, then press 



7. Firmware upgrade will run. Once finished press  to turn device OFF



## **REMOTE DISPLAY**

Laptop or tablet running Windows can be used as Remote display to control AVV-711

- connect AVV-711 to laptop/tablet via USB cable ("USB device" socket)
- wait until Windows mobile device center will detect AVV-711. Normally it takes few seconds (reconnect USB cable if not detected for a while)
- run Remote display utility (comes on CD)
- keyboard / touchscreen / mouse can be used to control AVV-711. AVV-711 keyboard can be used concurrently as well.

**STANDARD TOLERANCES OF SHAFT MISALIGNMENT**

This chapter provides the standards alignment tolerance of misalignment for standard industrial machinery with flexible coupling that can be used under condition only if existing in-house standards or the machine or coupling OEM have not given any blinding values, and must not be exceeded.

| Speed, rpm     | Good   |               | Acceptable |               |
|----------------|--------|---------------|------------|---------------|
|                | Offset | Angular (Gap) | Offset     | Angular (Gap) |
| Up to 1000     | 0,08   | 0,07          | 0,12       | 0,10          |
| Up to 2000     | 0,06   | 0,05          | 0,10       | 0,08          |
| Up to 3000     | 0,04   | 0,04          | 0,07       | 0,07          |
| Up to 4000     | 0,03   | 0,03          | 0,05       | 0,05          |
| More than 4000 | 0,02   | 0,02          | 0,04       | 0,04          |

**DELIVERY SET**

| Nº  | Description                     | Qty | Note |
|-----|---------------------------------|-----|------|
| 1.  | Control Display Unit            | 1   |      |
| 2.  | Measuring Transducer Units S, M | 2   |      |
| 2a. | Transducer's cable, 1.8m        | 2   |      |
| 3.  | Brackets Frame                  | 2   |      |
| 4.  | Chains assembly                 | 2   |      |
| 5.  | Supporting Rods                 | 8   |      |
| 6.  | USB wall Charger, 120-240Volts  | 1   |      |
| 7.  | Tape Measure 3m                 | 1   |      |
| 8.  | Carrying Case                   | 1   |      |
| 9.  | Operating Instructions Manual   | 1   |      |
| 10. | ConSpect Software               | 1   |      |
| 11. | USB PC Communication Cable      | 1   |      |