



qb701

LASER SHAFT ALIGNMENT SYSTEM

USER'S MANUAL

CONTENT

- General 4
 - Safety Precautions 4
 - Laser Safety Precautions 4
 - EC Declaration of conformity 5
- Technical Description 6
 - Designation 6
 - Misalignment Parameters 7
 - Specification and Features 8
 - System Package 9
 - System overview 9
 - Mounting Transducers 10
 - Laser Beam Adjustment 11
- Getting Started 12
 - Common control keys consideration 12
 - Auto save 12
 - Device setup 12
 - setup Menu Items 13
- Horizontal Machine Alignment 15
 - Short Explanation 15
 - Transducer's Positions Conventions 15
 - Parameters 16
 - Tolerance Setup 17
 - Taking Measurements. Clock Mode 18
 - Taking Measurements. Multipoint Mode 20

- Taking Readings. Auto Shooting mode 20
- Readings quality assessment 21
- Editing of measurement points..... 21
- Result Screen 22
- Movable machine Adjustment 23
- Machines with Spacer Shaft..... 24
- Lock Feet Pair 25
- Report file saving 26
- Soft Foot..... 27
- Vertical Machine Alignment 29
 - Short Explanation..... 29
 - Transducer's Positions Conventions 29
 - Parameters..... 30
- Taking Measurements. Clock Mode 31
- Result Screen 32
- Machine Correction @45 34
- Charging batteries..... 35
- Firmware Upgrade..... 36
- Firmware Upgrade Using Windows Mobile Device Center 38
- Standard Tolerances of Shaft Misalignment 40
- Delivery Set 41

GENERAL

SAFETY PRECAUTIONS

Be sure the machines to be measured, cannot be started unintentionally as this can cause injuries. For this purpose, before the mounting of equipment, either block the power switch in the "Off" position or remove the safety fuses. These precautionary rules must be followed until the measuring system is dismantled from the measured machine.

LASER SAFETY PRECAUTIONS

The KOHTECT qb701 alignment system is the class II laser device at typical wavelength of 650nm, delivered output power of less than 1 mW and maximum radiant energy per pulse of 0.1 mJ. The Class II laser comply with requirement outlined by USA's FDA as well as international ANSI, BS 4803 and IEC 825 standard. Be sure to follow the following safety precautions to avoid personal injuries and damage to the system

- ⚠ **Do not look directly into the laser beam at any time!**
- ⚠ **Do not direct laser beam on to the people's eyes!**



ATTENTION!

Do not expose qb701 parts to heavy impacts, high humidity and extreme temperature.

Do not try open / dismantle measuring units and the display unit – this can damage the system, and your after-sales service warranty will come void.

INJURY RESPONSIBILITY DISCLAIMER

Neither the Alvib Sistemas, SL enterprise nor our authorized dealers are liable for the damages caused to machinery or equipment by use of the qb701 system. We carefully check text of this manual to eliminate errors, nonetheless there may be mistakes or inaccuracy involved. We will be grateful for your reporting to us about any error, and we will be able to correct them in the subsequent editions of the manual.

EC DECLARATION OF CONFORMITY

Manufacturer: ALVIB Sistemas S.L., VAT: ES B10840346
Escorpora 24, 17252, Sant Antoni de Calonge, Spain

Product name: AVV-711

Description: Laser shaft alignment and geometrical measurement system

Model(s): AVV-711, AVV-711GEO

This declaration of conformity is issued under the sole responsibility of the manufacturer.

The object of the declaration described above is in conformity with the relevant Union harmonization legislation:

- 2014/30/EU – Electromagnetic Compatibility (EMC Directive)
- 2014/35/EU – Low Voltage Directive (LVD)
- 2011/65/EU – Restriction of Hazardous Substances (RoHS), including amendment (EU) 2015/863
- 2014/53/EU – Radio Equipment Directive (RED)

References to the relevant harmonized standards used:

EMC: EN 61326-1:2013, EN 55011:2016/A1:2017, EN 61000-6-2:2019,
EN 61000-6-4:2019

Electrical Safety (LVD): EN 61010-1:2010/A1:2019

Laser Safety: EN 60825-1:2014 (Laser Class 2)

RoHS: EN IEC 63000:2018

Radio: EN 300 328, EN 301 489-1, EN 301 489-17

Additional information:

The product incorporates low-power visible laser sources classified as Class 2, safe under reasonably foreseeable conditions of operation.

Signed for and on behalf of:

Place of issue: Sant Antoni de Calonge, Spain]

Date: 1 July, 2022

Name: Oleg Ivanov

Position: Director

Company: ALVIB Sistemas S.L.

Signature: 

TECHNICAL DESCRIPTION

DESIGNATION

qb701 alignment system (further as System) is designed for measurement of shaft axis misalignment of coupled machines, and calculation of movable machine adjustment required to eliminate misalignment that exceeds permissible tolerances;

The machine alignment means adjustment of the relative position of two coupled machines (e.g. motor and pump) so that the center line of the axis will be concentric when the machines are running under normal working conditions.

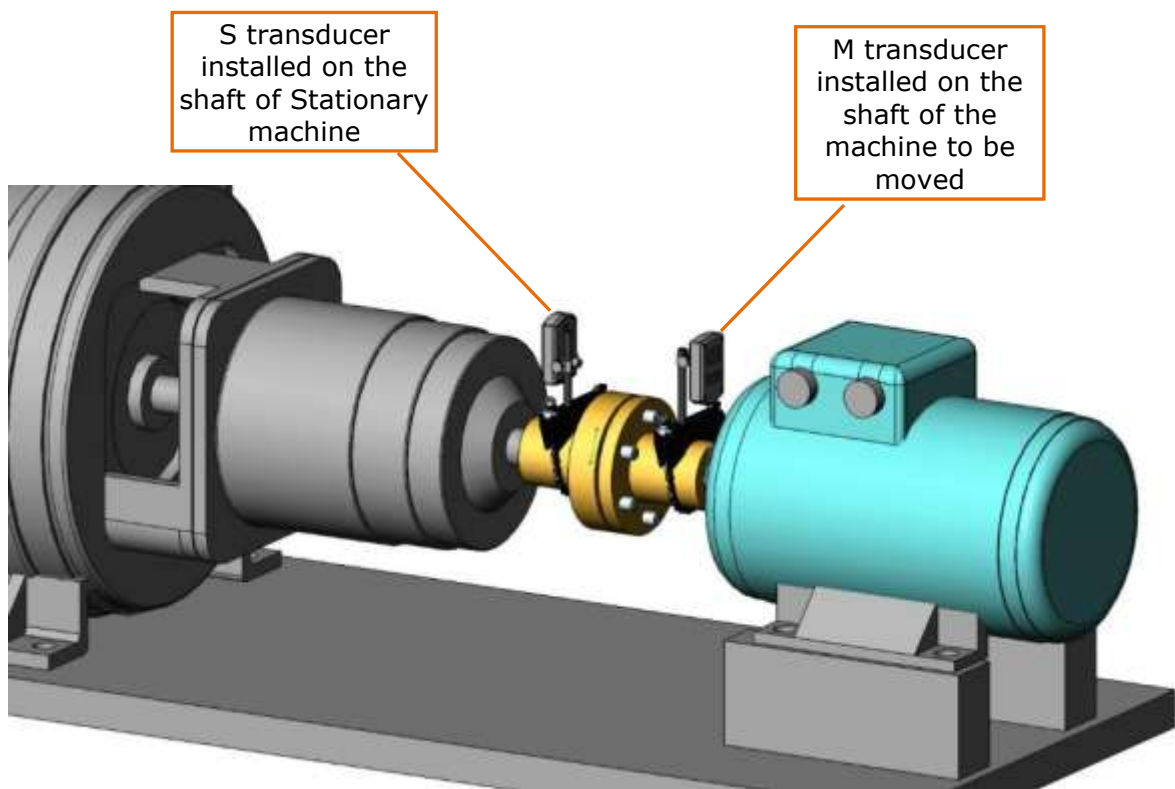

MISALIGNMENT PARAMETERS

Misalignment of any rotating machine is expressed in parallel (Offset) and angular (Gap) of the shafts. Most frequently in practice, both of them are present simultaneously. Different kinds of misalignment of axes are shown in Fig. 2.



	Parallel misalignment of axes – Offset (displacement)
	Angular misalignment of axes – Gap
	Parallel and angular misalignment of axes – (Offset + Gap)

Fig 2

The parallel (Offset) and angular (Gap) misalignment of axes is determined in two mutually perpendicular planes. For the purpose of elimination of the parallel and angular misalignment of axes, in each of the planes a correction of position of the movable machine (M) will be done.

For the horizontal mounted machine – the movable machine (M) position is adjusted in the horizontal and vertical planes.

For the vertical mounted machine, operator determines arrangement of the correction planes, basing on considerations of the convenience and technological effectiveness of moving of the movable (M) machine.

Stationary machine (S) - in the process of eliminating of the axes misalignment the position of this machine stay static, i.e. it does not move.

Movable machine (M) – the machine, which position is adjusted for eliminating of the parallel and angular misalignment of axes.

The measurement system calculates the values of the angular and parallel misalignment of axes in the plane of the coupling (in two mutually perpendicular planes), and the adjustment values for the machine feet on the movable (M) machine, that is necessary for elimination of this misalignment of axes. Fig. 3 shows misalignment of axes and the values for its correction just for vertical plane.

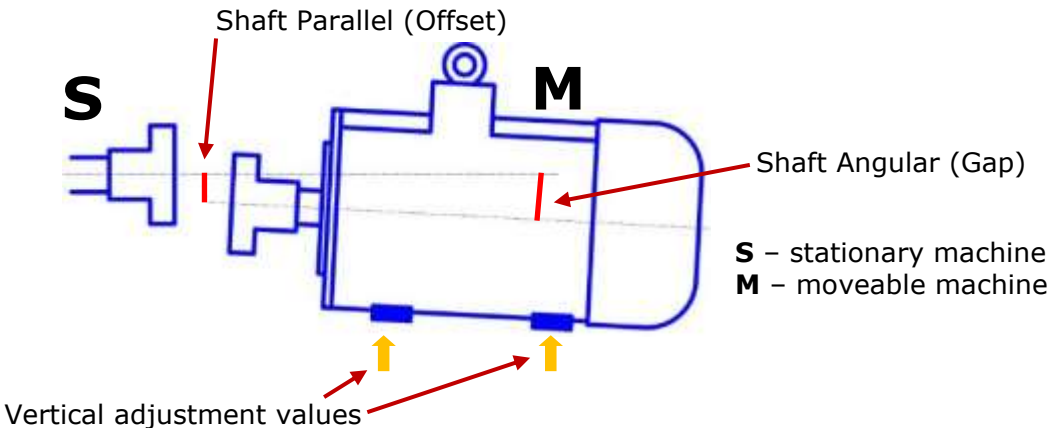

SPECIFICATION AND FEATURES

- Separation distance between measuring transducer units, up to 10 m
- Display unit operating temperature range, -10..+55 degree C
- Display unit and transducer's ingress protection level – IP65
- Measurement accuracy, 1%+0.01
- Laser type: Visible red 635-670 nm, <1 mW
- Detector type: CCD, length 30 mm
- Display resolution, 0.01 or 0.001 mm, (1 or 0.1 mil)
- Measuring resolution, 0.001mm
- Electronic inclinometer resolution, 0.1 degree
- Display unit battery: Rechargeable Li-Ion battery, 10hrs to recharge
- Transducers battery: Rechargeable Li-Po battery, 12hrs to recharge
- Gross weight, incl. carry case, 3.9 kg
- Built-in application programs and options:
 - o horizontal shaft alignment at any shaft position, from 60°, up to 360°, up to 36 readings can be measured; auto sweep mode can be used;
 - o vertical (flange machine) shaft alignment;
 - o editable misalignment tolerances;
 - o setup options;
 - o soft foot;
 - o thermal growth;
 - o shimming simulator to calculate for expected residual misalignment;

SYSTEM PACKAGE

The System includes (Fig. 1):

- 1- display unit
- 2- two measuring transducer units – S, M
- 3- universal V-brackets for transducers mounting extension chains for shafts up to 500mm dia stackable, allen key x2
- 4- measuring tape, 3m
- 5- 120...240 Volts AC charger
- 6- USB PC communication cable
- 7- Operating instructions manual and ConSpect freeware on the internal drive of display unit
- 8- Carrying case with form-inserted



SYSTEM OVERVIEW



MOUNTING TRANSDUCERS

- Firmly tighten rods 1 into the shaft brackets 2.
- Put thumb nut 3 into the bracket 2, then hook the chain 5 on the stud 4.
- Firmly tighten the thumb nut 3. Shaft brackets with rods must be mounted at the same angular position.
- Mount transducers on the rods. Always try to mount transducers at minimal possible radial height. Make sure that transducers are not touching brackets or machine parts.

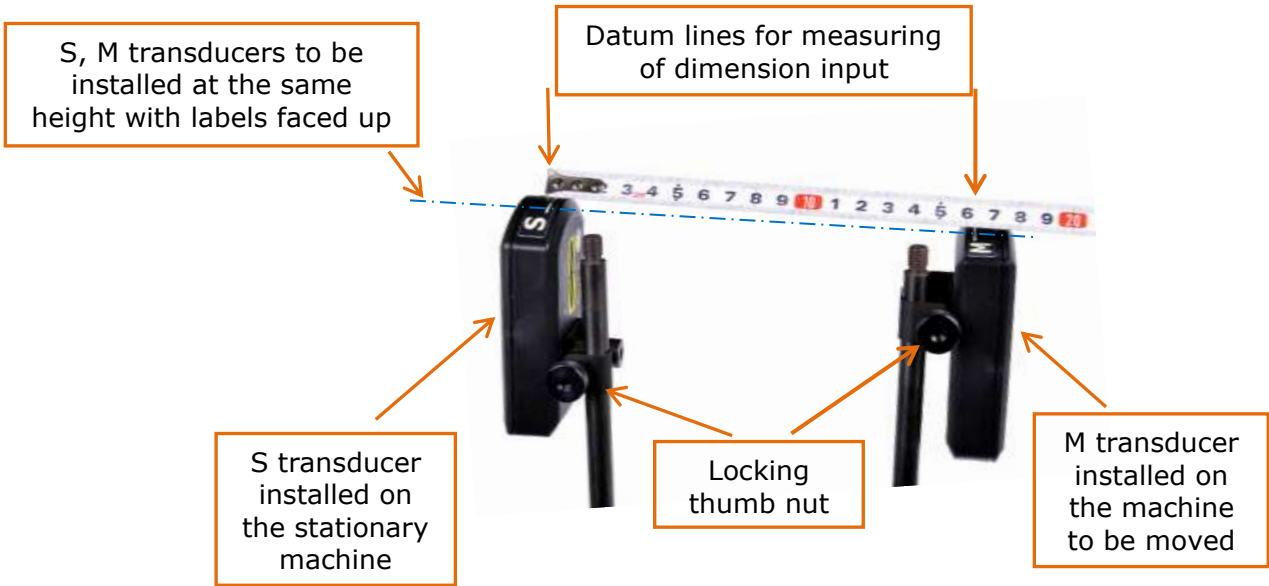
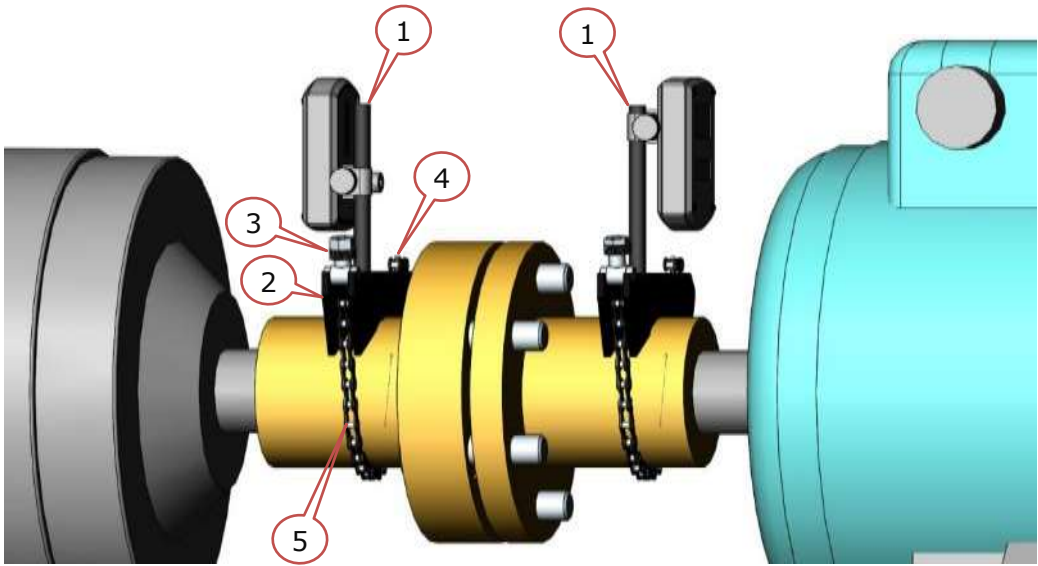

LASER BEAM ADJUSTMENT

- Loosen thumb nut and horizontally adjust transducer so the middle of the laser line is at the transducer's window.
- Slightly tighten thumb nut then vertically adjust laser line to the center of the transducer's window.
- Firmly tighten the thumb nut.
- Adjust second transducer in the same way.

Use an angular adjustment only. Do not change transducers installation height!





GETTING STARTED

COMMON CONTROL KEYS CONSIDERATION

To turn ON/OFF display unit and transducers – press and hold the power button  for ~2 sec.

In case the system hangs and device did not respond to any keys - press and hold the power button  for ~10 sec, the system will be reset.

To close any currently active window, without saving, except main menu of the device, press  button (it serves as escape key).



The  button in most cases causes applying (saving) changes (invoke selection) and exit (from edit box; or from current window, except such windows as collect data, aligning, soft foot and so on where it is not applicable).

To invoke menu item – move cursor to this item and press  key, or just press the shortcut key regardless of the cursor position. In most cases the shortcut key is depicted left to the menu item.

AUTO SAVE

All procedures are designed with auto save. For temporarily shut down your current work press  until program exits to main menu of the device. Data saved now and device can be turned off.

DEVICE SETUP

To invoke Setup menu – move cursor to Setup icon and press  button, or press  key.

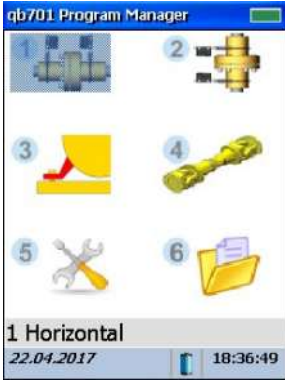

SETUP MENU ITEMS



1. setup date & time - to setup date and time

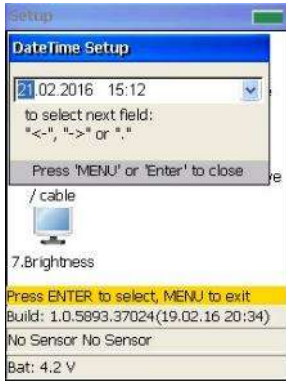

2. power manager - to set device auto off delay in seconds. When set to 0 - auto off is disabled.



3. license manager - to install license file which enables measurement functions. Press 9, browse to the license file, press Enter to open and install licenses.

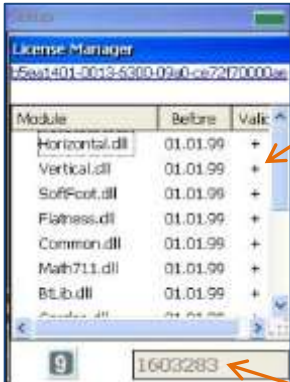

+ Function enabled, valid until 01.01.2099

Serial number



4. wireless /cable - to switch between wireless/cable transducers connection. For wireless connection - press 1 or 2 to enter number of transducers to be connected

Number of transducers to be connected

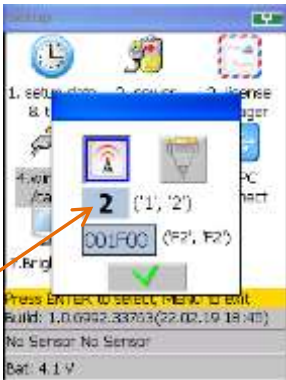



- to choose user interface language

Use keys to choose language, then press



- to switch qb701 into USB mass storage device mode. By default device can be connected to the PC via Microsoft Windows Mobile Device Center. USB mass storage device mode can be used as alternative.



- to adjust the display backlight brightness

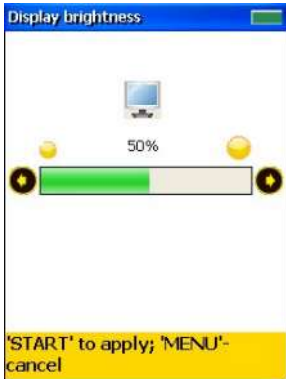

- to choose default alignment biaxial mode. In biaxial mode both horizontal and vertical machine aligning with live data update could be made at a static transducers position (e.g. 3 h). For QB-TSM transducers the only available mode is 1-D.



mode 1-D or 2-D

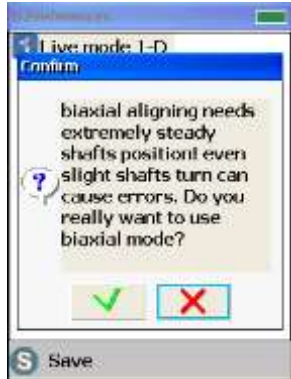

HORIZONTAL MACHINE ALIGNMENT

SHORT EXPLANATION

- Mount transducers on shafts
- Run Horizontal program
- Enter dimensions
- Set parameters. E.g. Measurement mode – clock type (9-12-3 o'clock positions)
- Turn shafts with transducers at first position 9 o'clock (90°). Press Start to take readings
- Turn shafts with transducers at second position 12 o'clock (180°). Press Start to take readings
- Turn shafts with transducers at last position 3 o'clock (270°). Press Start to take readings
- After that device will calculate misalignment and displays required corrections for Movable machine

TRANSDUCER'S POSITIONS CONVENTIONS

While taking measurements, it is necessary to follow conventions for transducers positions on the shafts with the S and M measuring transducers with regard to the relative position of the S and M machines as depicted on the figure.

Angular positions in degrees adopted in the device are as follows:

6 o'clock - 0°

9 o'clock - 90°

12 o'clock - 180°

3 o'clock - 270°

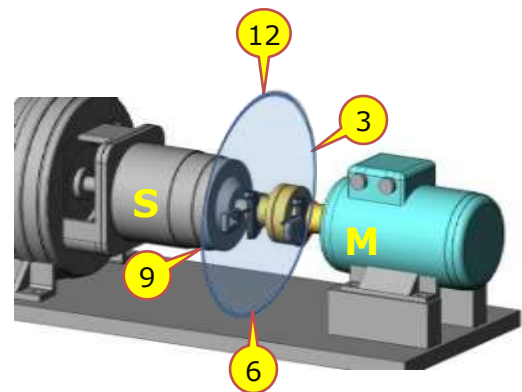

PARAMETERS

In Main Menu run **Horizontal** program.

Choose **New Task**.

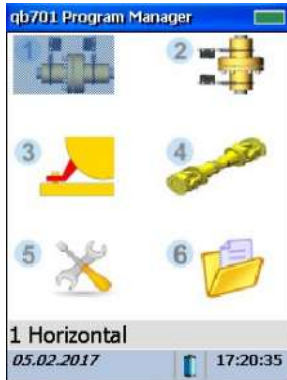

Machine dimensions / measurement setup screen

Press key to start editing of the dimensions values

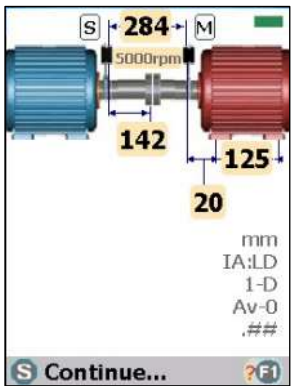

Press key for parameters/key legend:

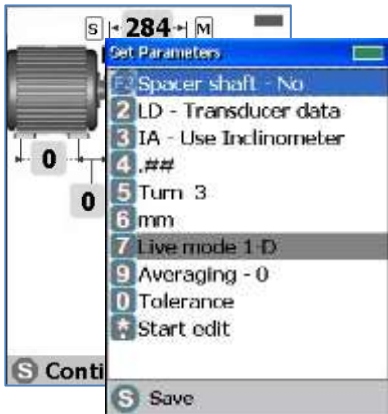

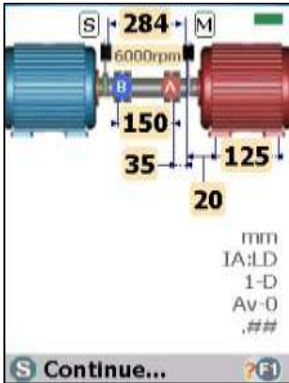
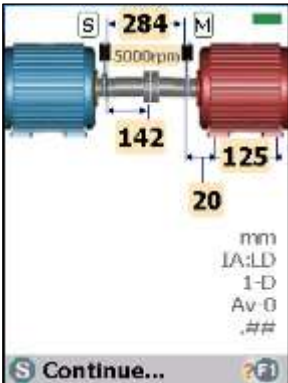

Press - to toggle Spacer shaft
Yes/No



Press  - to toggle data input – **LD** transducer's data / **MD** – manual data

Press  - to toggle angle input – **IA** use inclinometer / **MA** manual angle. Manual angle input used for vertical machines, when electronic inclinometer cannot be used.

Press  - to toggle displayed precision – 2 or 3 digit.

Press  then  - to toggle measurement mode:

Turn 3 - clock mode **9-12-3 o'clock** – readings to be taken at three predefined shaft positions – 9 o'clock, then 12 o'clock, then 3 o'clock. After that, device will proceed to the result screen.

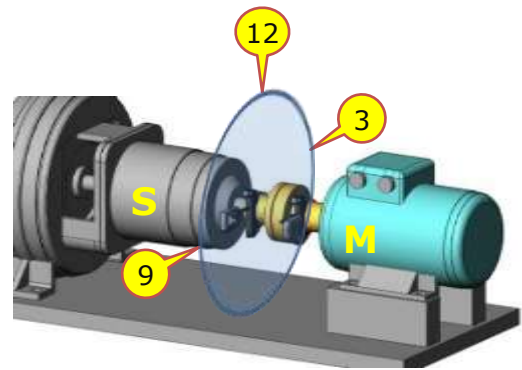

Turn 4 points – readings to be taken at four predefined shaft positions separated by 90° or 45° (3hr / 1:30hr). After that the device will proceed to the result screen.



Multipoint mode – measurements may be taken at any of minimum 3 up to 36 positions. After taking enough readings one should press  to proceed to the result screen.

TOLERANCE SETUP

Press  to enter tolerance setup menu.

Press  to use predefined RPM/tolerance table

Press  to enter user defined tolerance values

Press  to save changes,  to discard changes.

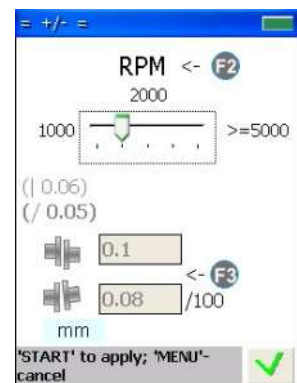

TAKING MEASUREMENTS. CLOCK MODE

Press to edit dimensions.

Set parameters and enter dimensions then press key to proceed.

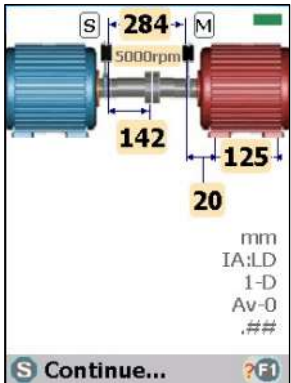

Turn shafts to first position – 9 o'clock (90°)

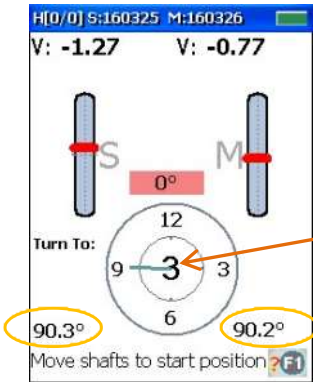
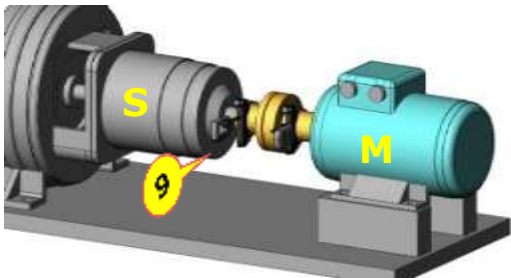

3 - clock mode
* - multipoint

Press to take first reading.

First measurement

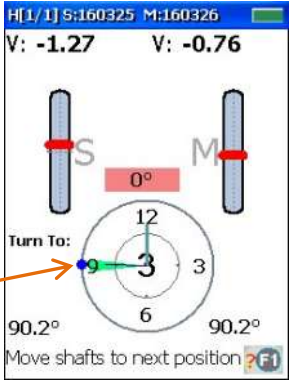

Turn shafts to second position – 12 o'clock (180°)

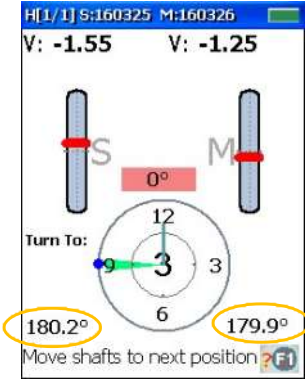
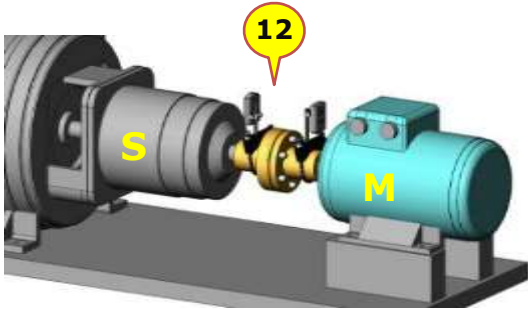

Press  to take second reading.

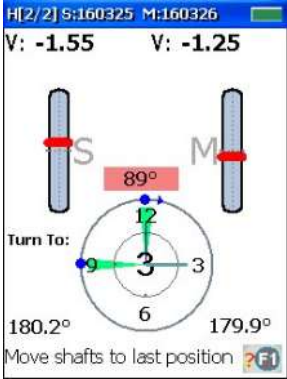

Turn shafts to third/last position – 3 o'clock (270°)

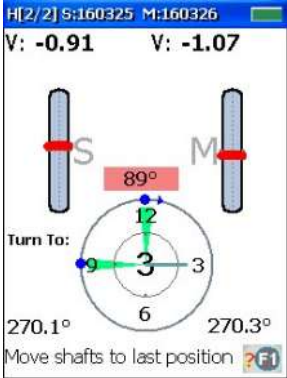
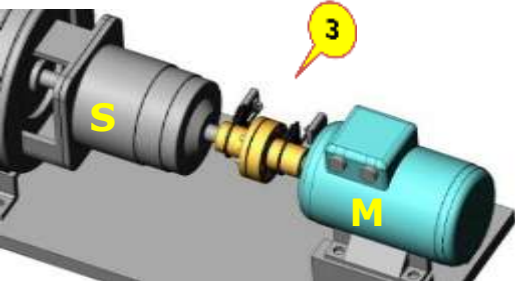

Press  to take third reading.

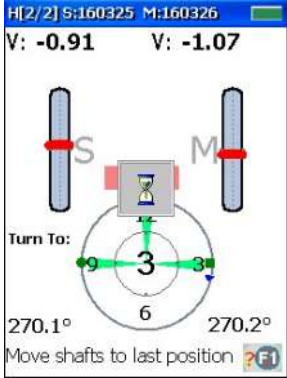

When three reading are taken device will proceed to the result screen.

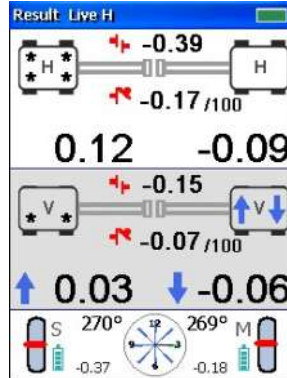

TAKING MEASUREMENTS. MULTIPOINT MODE

In multipoint mode readings can be collected at any shafts position minimum 3 up to 36 positions.

qb701 is able to calculate misalignment after collecting at least 3 points within as little as 70 degree range. **However always try to cover as wide shaft turn angle as possible.**

Press  to take reading, and then turn shafts to next position.

Yellow clock face means that point is already collected and shafts should be turned to next position.

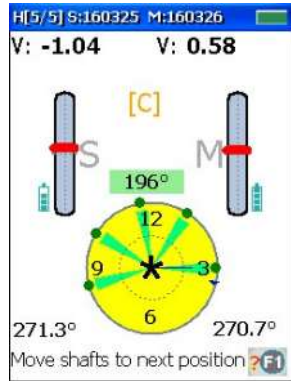
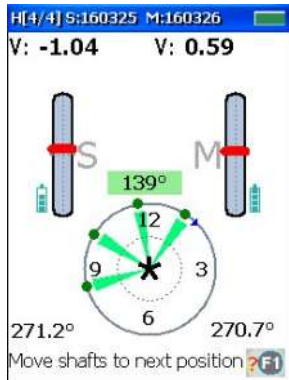

When enough readings are collected – press  to proceed to the result screen.

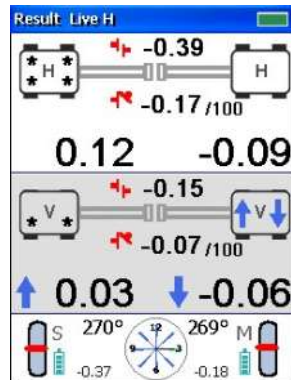

TAKING READINGS. AUTO SHOOTING MODE

Turn shafts to first position, then press  to activate auto shooting mode.

Auto shooting mode is active

When auto shooting mode is active – device waits for stable shaft position then automatically records data and prompts to move shafts to the next position.

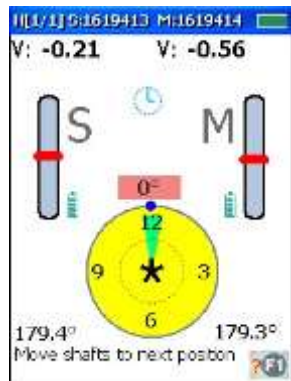
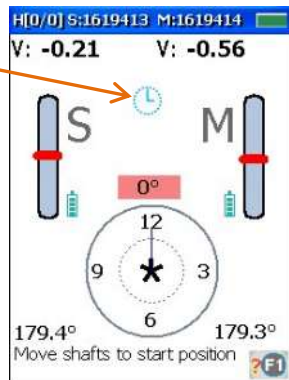

Auto shooting mode can be activated in both Clock mode and Multipoint mode.

When device is in Multipoint mode and enough readings are collected – press **F5** to proceed to the result screen.

When device is in Clock mode and three/four readings are taken device will automatically proceed to the result screen.

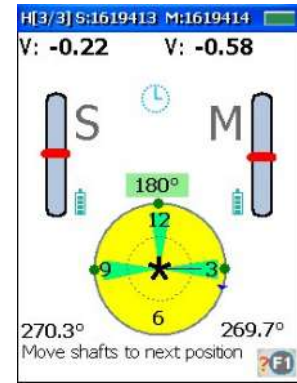

READINGS QUALITY ASSESSMENT

While taking readings device performs assessment of data quality based on standard deviation. Quality is indicated by color of dots at measurement positions:

Blue – assessment is impossible (too few points collected)

Green – good quality

Yellow – acceptable quality

Red – poor quality, must be re-measured.

The factors which may affect readings – high vibration, partial clipping of the laser beam, mechanical looseness, accidental alteration of transducers position (e.g. by touching it).

Readings quality assessment is useful option which helps to detect such conditions.

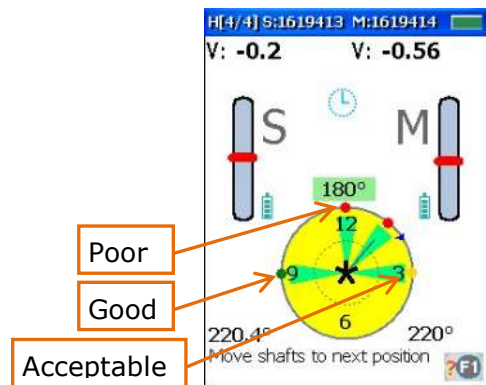

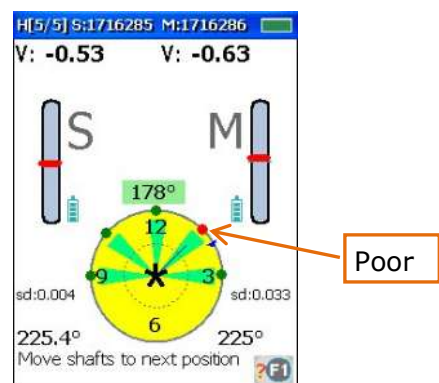

EDITING OF MEASUREMENT POINTS

It is possible to edit collected data when poor quality data is detected.



Press  key to activate edit mode

Use   keys to scroll over collected readings

Edit mode

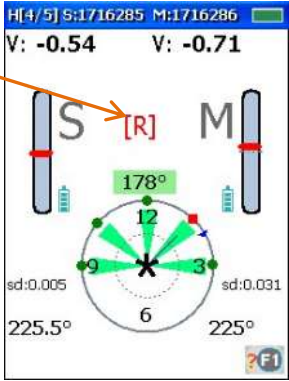

Use  to delete readings

Use  key to quit edit mode (press until cursor points to the last measurement, then quit)

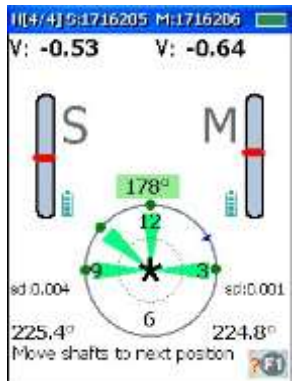
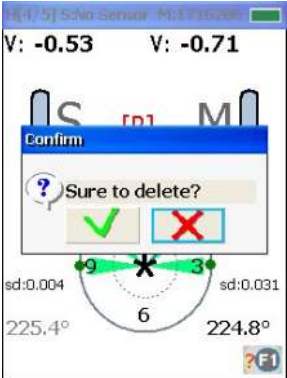

RESULT SCREEN

On the result screen device displays parallel and angular misalignment at the coupling and values of the required corrections in horizontal and vertical directions for movable machine. Blue arrows clearly displays directions in which movable machine must be moved to eliminate misalignment.

Parallel and angular misalignment at the coupling

Values and directions of adjustment for Front and Rear feet

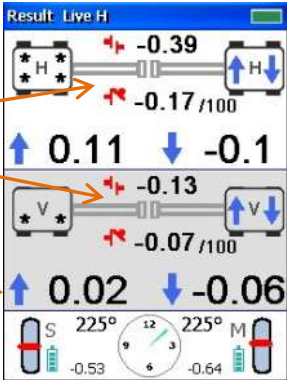

Horizontal adjustment: **Top** view at the Movable machine

Vertical adjustment: **Side** view at the Movable machine

MOVABLE MACHINE ADJUSTMENT

To make adjustment in **vertical** direction transducers must be turned to 6 or 12 o'clock (0° or 180°) position.

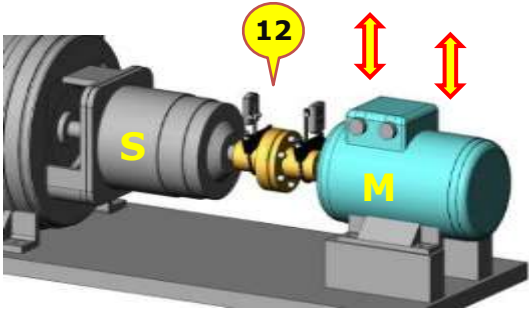

To make adjustment in **horizontal** direction transducers must be turned to 9 or 3 o'clock (90° or 270°) position.

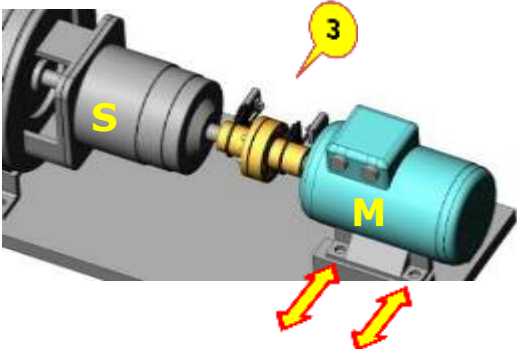

Device may reduce number of available transducers positions for machine adjustment. Permissible transducer positions are indicated at the clock face. Only permissible transducer positions can be used for machine adjustment.

Transducers now at 3 o'clock (270°) live data for H direction

Data for V direction are frozen (display shaded) until transducers are not turned to 12 or 6 o'clock

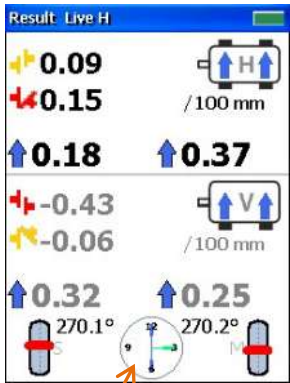

Permissible transducer positions –
12, 6 – for V direction
3 – for H direction

MACHINES WITH SPACER SHAFT

Press **F3** to activate Spacer Shaft option.

Procedure and options are the same as for Horizontal program.

Enter machine dimensions.

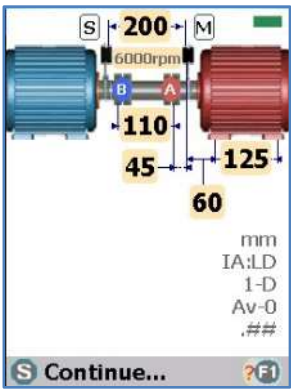

Collect readings.

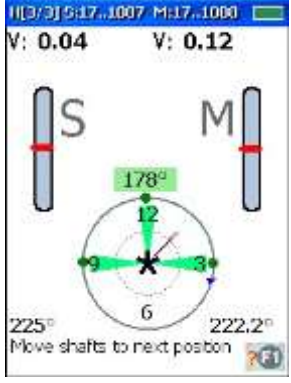
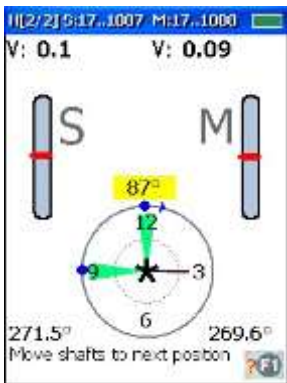
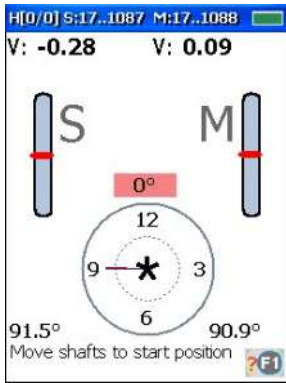

Make moveable machine correction.

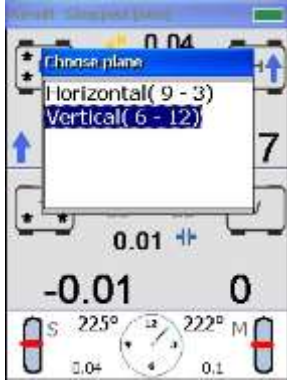
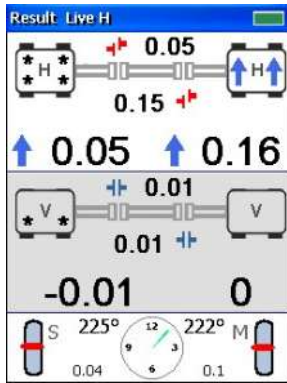

LOCK FEET PAIR

In some cases could be practical to swap movable machine. This function is applicable for Machines with and without Spacer shaft.

Press  key. Device will prompt to enter missed dimensions.

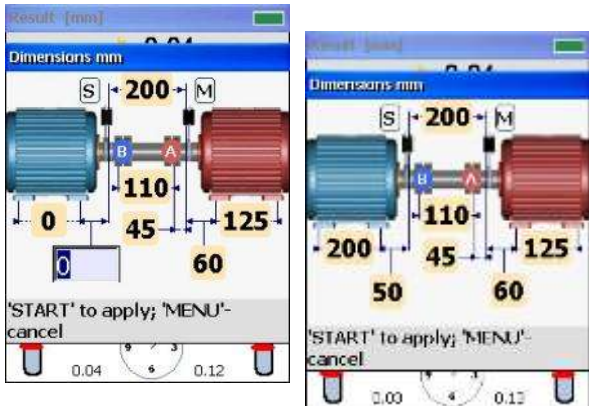

Press  key to lock feet pair.

Press  to apply.

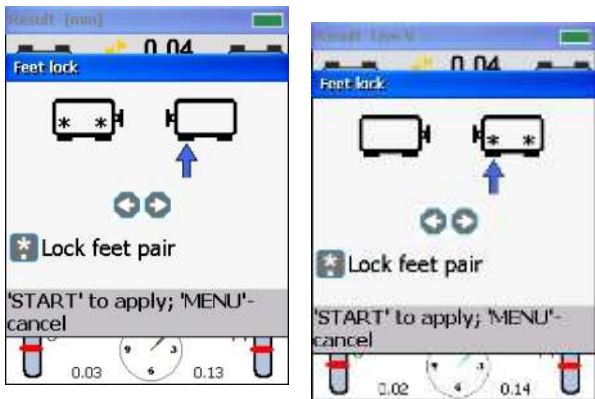

Machine to be moved

Static Machine

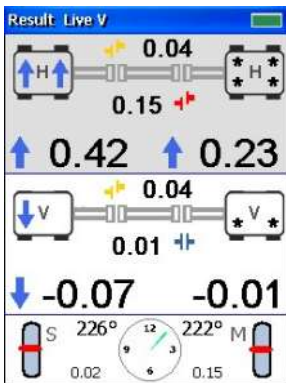



REPORT FILE SAVING

Report file can be saved at any stage of alignment

To save report file – press  key in the result screen

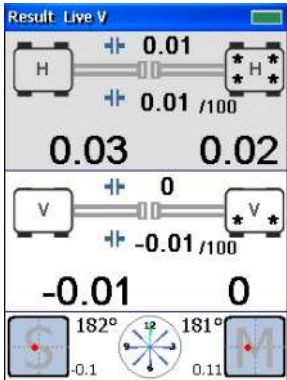
Reports can be saved to internal SD card or to thumb drive connected to USB host socket of the AVV-711 display unit



Use  key to choose drive

Use       keys to browse folders



Use  to open folder

Use  to move one level up

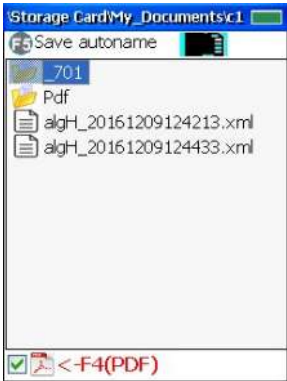

Use  to create new folder

Use  to turn on/off PDF reports generation

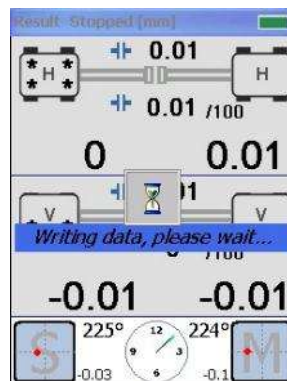

Press  or  key to save report with default name



Press  to edit file name, then press  to save file

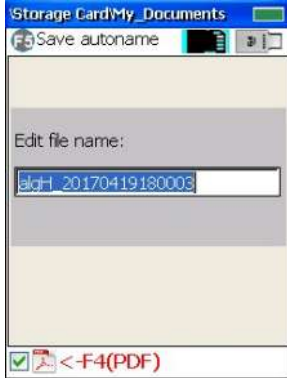

SOFT FOOT

Soft foot condition makes impossible proper machine alignment. So it should be eliminated prior to conduct alignment work. Soft Foot program intended for this purpose.

In Main Menu run **Soft Foot** program.

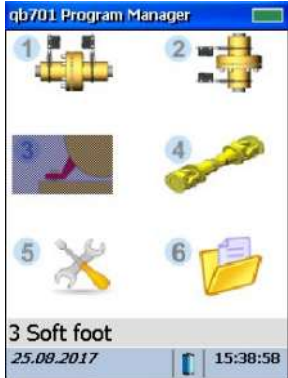

Enter distances

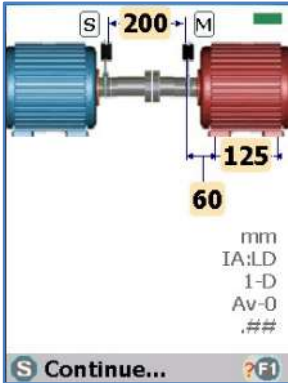



Make sure that all foots are tightened.

Turn shafts with transducers at 12 o'clock position.

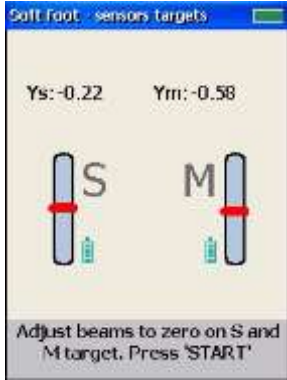
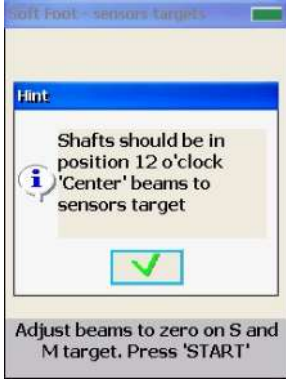
Press  key to proceed.



- Loosen first bolt fully
- Wait about 5 sec
- Press  key
- Tighten bolt firmly
- Press  key
- Loosen second bolt fully

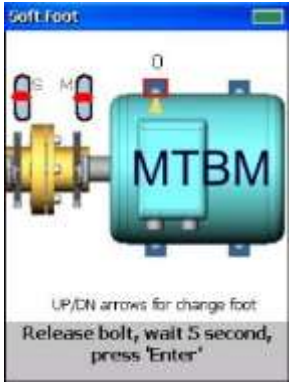

- Wait about 5 sec
- Press  key
- Tighten bolt firmly
- Press  key

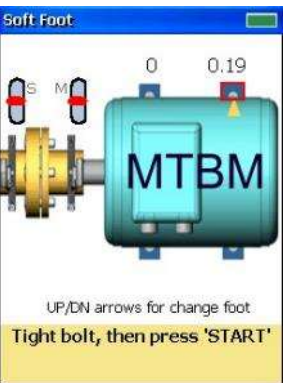

- Loosen third bolt fully
- Wait about 5 sec
- Press  key
- Tighten bolt firmly
- Press  key

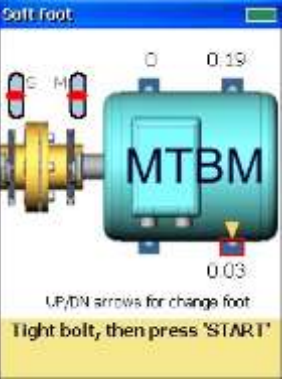
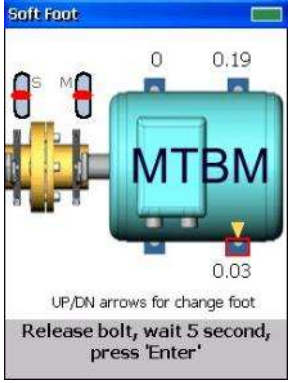

- Loosen fourth bolt fully
- Wait about 5 sec
- Press  key
- Tighten bolt firmly
- Press  key

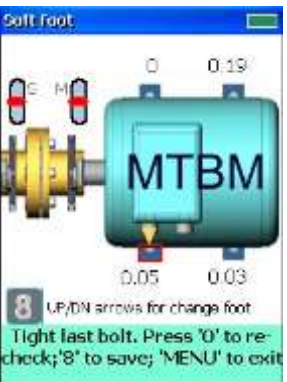
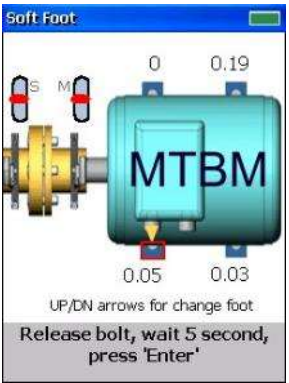

Bolt selection sequence can be changed by manually selecting the bolt by arrow keys.

VERTICAL MACHINE ALIGNMENT

SHORT EXPLANATION

- Mount transducers on shafts
- Run Vertical program
- Mark on the machine three positions spaced by 90° (9-12-3 o'clock positions)
- Enter dimensions
- Set parameters. E.g. Tolerances.
- Turn shafts with transducers at first position 9 o'clock (90°). Press Start to take readings
- Turn shafts with transducers at second position 12 o'clock (180°). Press Start to take readings
- Turn shafts with transducers at last position 3 o'clock (270°). Press Start to take readings

After that device will calculate misalignment and displays required corrections for Movable machine

TRANSDUCER'S POSITIONS CONVENTIONS

While taking measurements, it is necessary to follow conventions for transducers positions on the shafts with the S and M measuring transducers with regard to the relative position of the S and M machines as depicted on the figure.

Angular positions in degrees adopted in the device are as follows:

6 o'clock - 0°

9 o'clock - 90°

12 o'clock - 180°

3 o'clock - 270°

The electronic inclinometers cannot be used on the vertical machines, so "Manual angle" is set by default. One should mark measurement positions on the machine prior to start measuring.

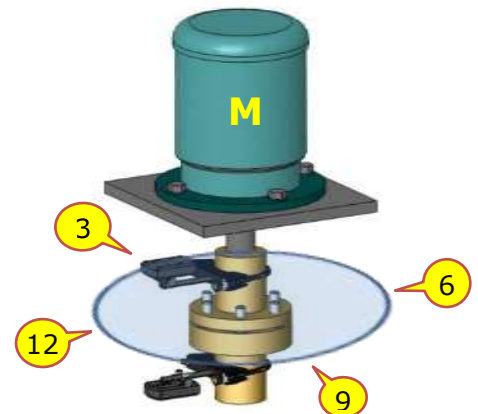

PARAMETERS

In Main Menu run **Vertical** program.

Choose **New Task**.

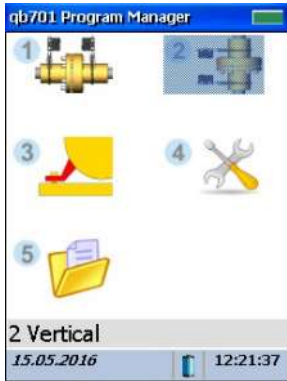

Machine dimensions / measurement setup screen

Press key to edit dimensions values

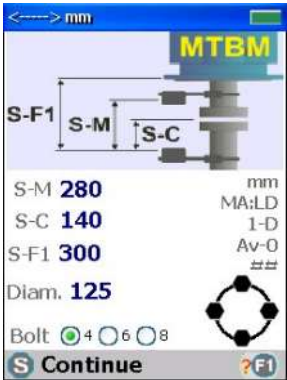

Press key for parameters/key legend:

Press - to toggle data input – LD transducer's data / MD – manual data

Press - to toggle angle input – IA use inclinometer / MA manual angle. Manual angle input used for vertical machines, since electronic inclinometer cannot be used.

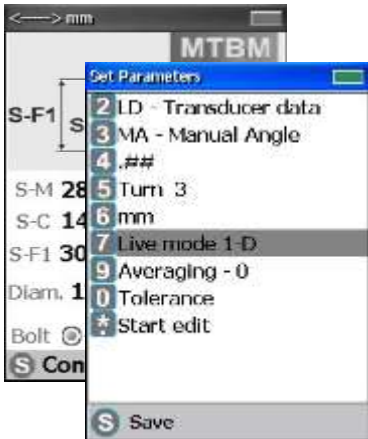

Press - to toggle displayed precision – 2 or 3 digits.

Press - to toggle measurement mode: Clock mode **9-12-3 o'clock** – readings to be taken at three predefined shaft positions – 9 o'clock, then 12 o'clock, then 3 o'clock. Device will proceed to the result screen then.

Press to switch displayed units mm/inch

Multipoint mode – measurements may be taken at any minimum 3 up to 36 positions.

After taking enough readings one should press **F5** to proceed to the result screen. For Vertical machines inclinometer data is unavailable, so angle value for each point should be entered manually, taking into account mentioned above positions conventions.

Press **DEL** to enter tolerance setup menu.

Press **F2** to use predefined RPM/tolerance table

Press **F3** to enter user defined tolerance values

Press **START** to save changes, **MENU** to discard changes.

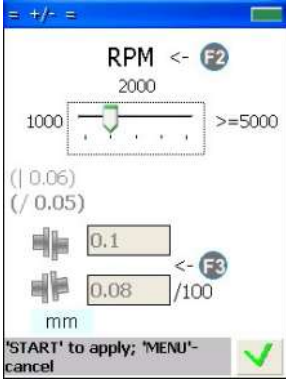

TAKING MEASUREMENTS. CLOCK MODE

Press ***** to edit dimensions.

Mark on the machine measurement positions separated by 90° (or 45°)

Set parameters and enter dimensions then press **START** key to proceed.



Turn shafts to first position – 9 o'clock (90°)

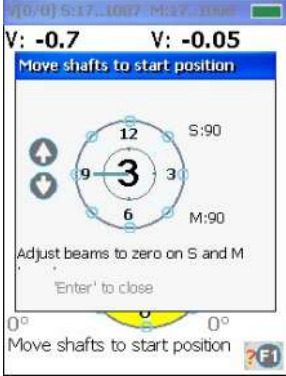
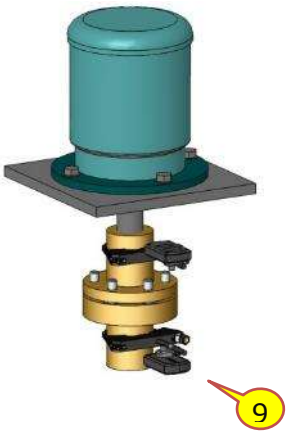

Press **START** to take first reading.

Arrow keys  can be used to choose actual measurement position

Turn shafts to second position – 12 o'clock (180°)

Press  to take second reading.



Turn shafts to third/last position – 3 o'clock (270°)

Press  to take third reading.

Measurement position selection window can be closed by  key.

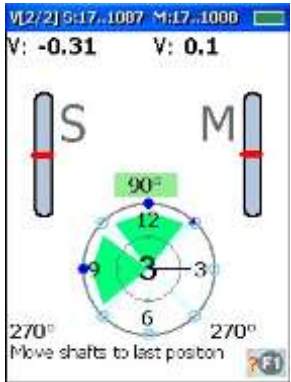
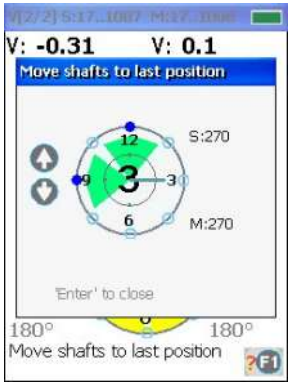

When three reading are taken device will proceed to the result screen.

RESULT SCREEN

At this moment transducers are at 3 o'clock (270°) position – so device displays live updated values for 9-3 direction.

The result screen shows the following data:

- Parallel misalignment: 0.46 (red arrow pointing right)
- Angular misalignment: 0.18 /100 (red arrow pointing right)
- Required parallel correction: 0.46 (blue arrow pointing left)
- Parallel misalignment: -0.16 (red arrow pointing left)
- Angular misalignment: -0.05 /100 (yellow arrow pointing left)
- Required parallel correction: -0.16 (blue arrow pointing up)

 At the bottom, there are shaft indicators 'S' and 'M' with values 0.54 and 0.46 respectively, and a circular dial showing the 3 o'clock position.

 Callout boxes provide further explanation:

- 'Values of parallel and angular misalignment' points to the top two rows of data.
- 'Values and direction of required parallel correction' points to the blue arrows in the middle two rows.

Blue arrows are displaying directions in which movable machine must be moved to eliminate parallel misalignment.

Keys legend can be invoked by  key

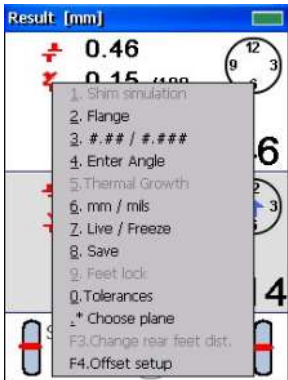

Press  key to toggle between parallel/shimming values screens.

Shimming values

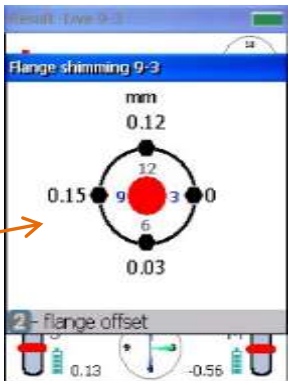

Press  key to choose plane (9-3 or 12-6) in which parallel correction will be performed.

To make correction in 9-3 plane transducers must be placed at 9 or 3 o'clock position.

To make correction in 12-6 plane transducers must be placed at 12 or 6 o'clock position.

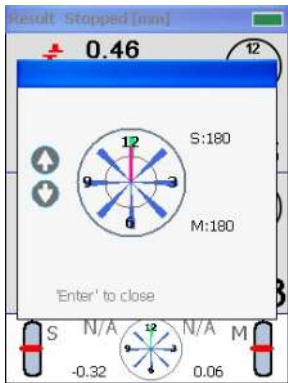



Use arrows keys   to choose position at which transducers will be placed.

Turn shafts to place transducers in this position then press  key.

MACHINE CORRECTION @45

In order to exclude the need to turn the shafts when switching correction plane, transducers can be placed at one of 45° positions: 10:30, 1:30, 4:30, 7:30 o'clock. This option can be used on Horizontal and Vertical machines.

Use arrows keys   to choose position at which transducers will be placed, then press  key.

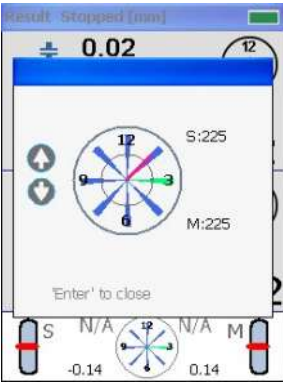

Live alignment at 12-6 plane.

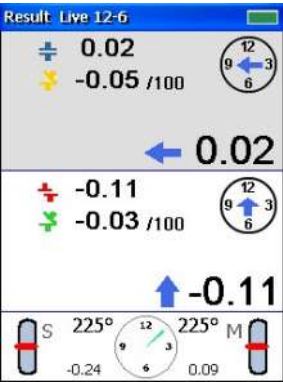

Press  key to choose 9-3 plane.

There is no need to turn shafts in this mode. Transducers can be at static 45° position.

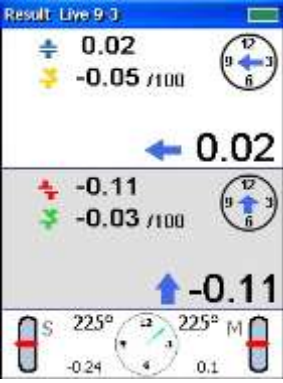
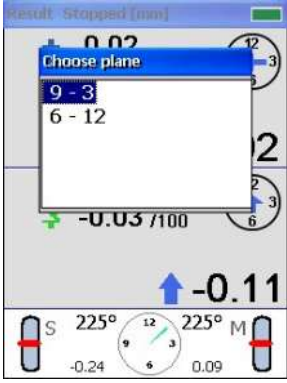

Color of coupling signs indicates value of misalignment. Green color indicates when residual misalignment is within tolerance. Black color is for perfect result. Always stop machine correction when residual misalignment is within tolerance. Do not try to reach zero.

CHARGING BATTERIES

The battery can be charged by means of USB type AC charger or via PC/laptop USB port.

Immediately after connecting charger to the display unit there are few seconds to change charge current - press and hold ON button for ~2sec until LED changes flash rate.



Low flash rate - normal charge, high rate - fast charge. Keep in mind that PC/laptop USB port can only provide normal charge.

Charging will be terminated and the LED will turn off when battery is fully charged. No overcharge occurs in case the USB cable is left connected.



FIRMWARE UPGRADE

Make sure that device battery is fully charged!





- 1. Insert USB thumb drive into PC/Laptop port. In the root directory of USB thumb drive – create the folder **AvvUpd.ate**



- 2. Copy firmware file **Avv711Intall.cab** to this folder



- 3. Remove USB thumb drive from PC/Laptop port and insert it to the qb701 USB host port. Press and hold  key for ~2 sec to turn qb701 on.



- 4. Invoke firmware updater by pressing     keys simultaneously.

- 5. Press  to conform search for USB



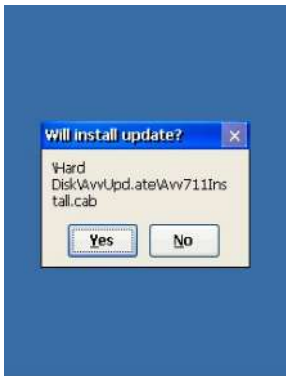

- 6. Press  to confirm start of firmware upgrade.

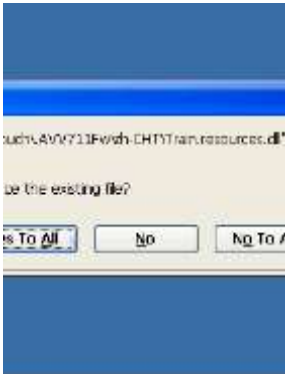

7. Press  key then  to confirm replace of all existing files



8. Press  key to choose NO, then press 



9. Firmware upgrade will run. Once finished press  to turn device OFF



FIRMWARE UPGRADE USING WINDOWS MOBILE DEVICE CENTER

Make sure that device battery is fully charged!



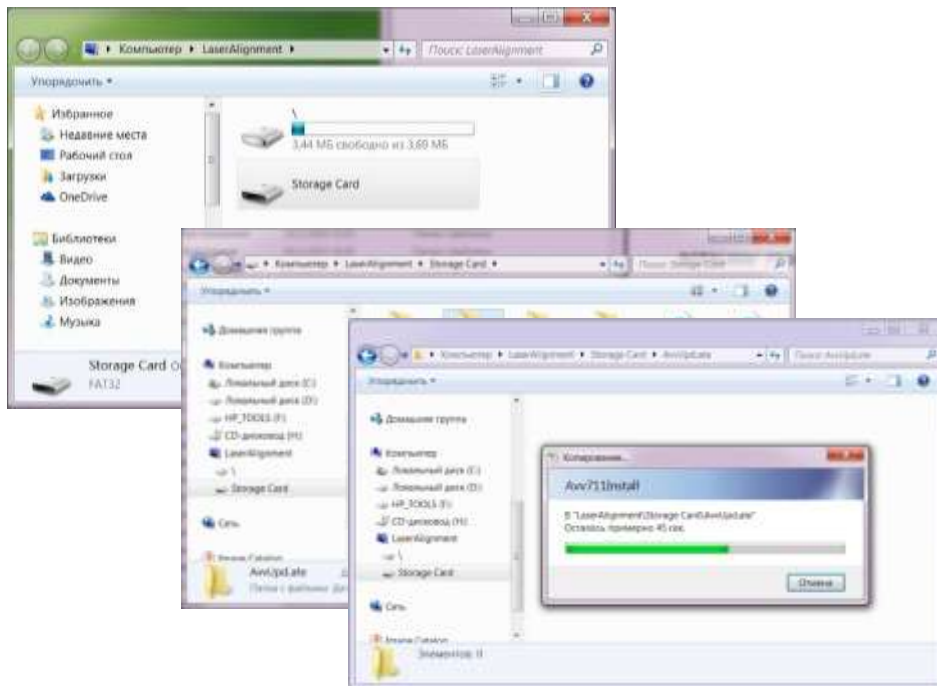

1. Connect AVV-711 to PC via USB cable. Press and hold  key for ~2 sec to turn qb701 on. Windows Mobile Device center will launch. Connect to qb701 and browse to the folder

"Storage Card/LaserAlignment/AvvUpd.ate/"

Avv711Install.cab





2. Wait until file copied.

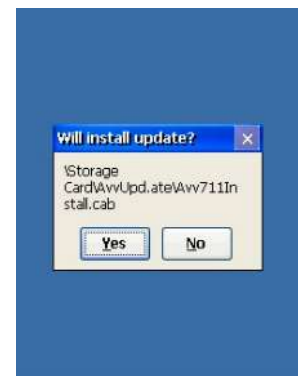

3. Invoke firmware updater by pressing     keys simultaneously.

4. Press  to confirm start of firmware upgrade.

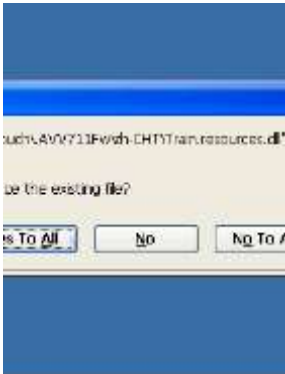

5. Press  key then  to confirm replace of all existing files



6. Press  key to choose NO, then press 



7. Firmware upgrade will run. Once finished press  to turn device OFF



STANDARD TOLERANCES OF SHAFT MISALIGNMENT

This chapter provides the standards alignment tolerance of misalignment for standard industrial machinery with flexible coupling that can be used under condition only if existing in-house standards or the machine or coupling OEM have not given any blinding values, and must not be exceeded.

Speed, rpm	Good		Acceptable	
	Offset	Angular (Gap)	Offset	Angular (Gap)
Up to 1000	0,08	0,07	0,12	0,10
Up to 2000	0,06	0,05	0,10	0,08
Up to 3000	0,04	0,04	0,07	0,07
Up to 4000	0,03	0,03	0,05	0,05
More than 4000	0,02	0,02	0,04	0,04

DELIVERY SET

Nº	Description	Qty	Note
1.	Control Display Unit	1	
2.	Measuring Transducer Units S, M	2	
3.	Brackets Frame	2	
4.	Chains assembly	2	
5.	Supporting Rods	4	
6.	AC Charger, 100-240Volts	1	
7.	Tape Measure 2m	1	
8.	Carrying Case	1	
9.	Operating Instructions Manual (on internal SD card)	1	
10.	ConSpect Software (on internal SD card)	1	
11.	USB PC Communication Cable	1	